

BD Screw jack

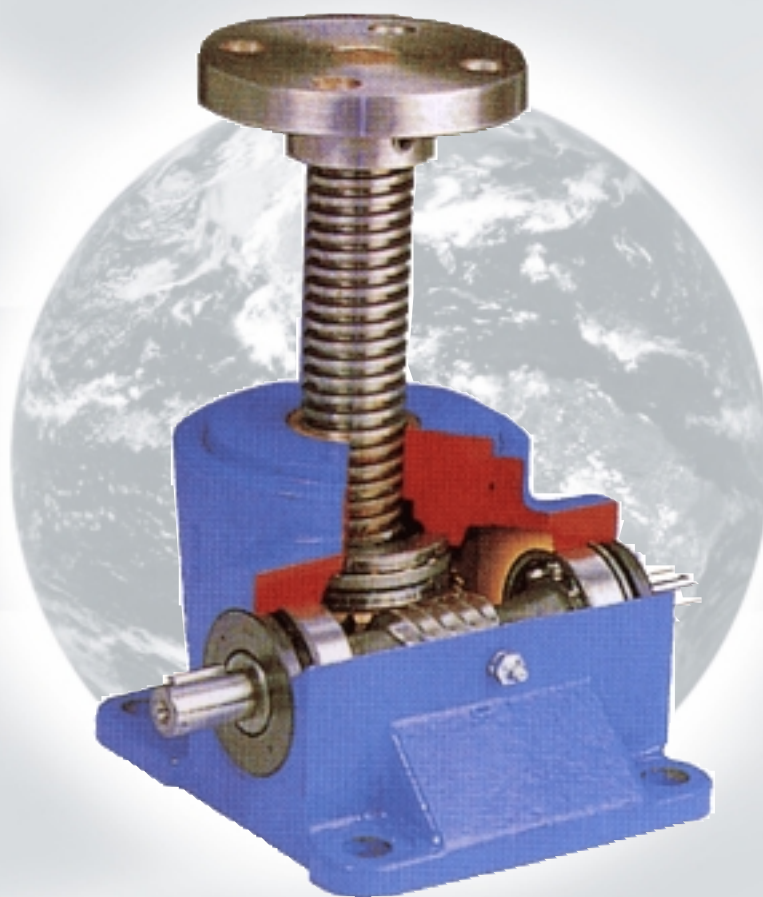

Benzlers develops, manufactures and supplies equipment for power transmission and linear motion to the world market.

Benzlers

Benzlers is a leading manufacturer and supplier of power transmission equipment around the world. For over 50 years, our customers have gained the benefit of our experience and our products to satisfy their power transmission demands.

Quality products with high reliability and long durability are something that we feel should go without saying. We pride ourselves on short delivery times, high delivery reliability and the best possible service to our customers.

We have a well established market and service organisation with subsidiaries and agents in Europe and all over the world. This is important for internationally active companies who are searching for the right power transmission supplier.

This catalogue will help you select suitable products for your applications. Naturally, you are always welcome to contact our specialists for advice and solutions. We can also offer you CAD diskettes as support in your own work in CAD systems.

Welcome to Benzlers !

Contents

Introduction.....	3
Standard and variant executions	4
Selection guide.....	6
Determination of type.....	7
Selection of jacks.....	8
Technical data BD - BDL	9
Power ratings BD - BDL.....	14
Dimensions BD - BDL	26
Options.....	30
Technical data BDK - BDKL	34
Power ratings BDK - BDKL	36
Dimensions BDK - BDKL.....	39
IEC motorflange.....	44
Example of arrangements	45
Benzler universal joint shaft	46
Bevel gears.....	47
Telescopic spring protection.....	50
Mounting and maintenance instructions.....	51

Introduction

Benzlers is a company in the transmission field with comprehensive experience in manufacturing and marketing MECHANICAL WORM GEAR SCREW JACKS, and complete screw jack systems.

With this catalogue we have made it easy to select a screw jack or screw jack system suitable for your application. You can also consult our Technical Sales and Engineering department. They will help you with computer calculations and suggestions, for both standard and special applications.

Being an international company, we are able, through our own subsidiaries and active agents, to give the optimum solution, on a local basis.

Please refer to the back page of this publication for details of the BENZLER company operating on your market.

BD and BDL

Mechanical worm gear screw jack with trapezoidal lifting screw available with translating lifting screw or lifting nut.

8 standard sizes.

Capacities up to 1000 kN (100 tonne)

1500 kN (150 tonne) on request.

Lifting speed up to 2.4 m/min (40 mm/s).

Double speed with two-start lifting screw.

Standard lifting screw length up to 4 m.

Longer on request.

Self locking in the majority of non vibrating operating conditions, consult your BENZLERS engineer for further details.

Small side loads accepted only on type BD, consult your BENZLERS engineer.

BDK and BDKL

Mechanical worm gear ball screw jack, available with translating lifting screw or lifting nut.

Capacities up to 125 kN (12.5 tonne).

200 kN (20 tonne) with ball screw available on request.

500 kN (50 tonne) with roller screw available on request.

Lifting speeds up 5.4 m/min (90 mm/s)

Faster on request.

Standard lifting screw length up to 5.5 m.

Not self locking, must be combined with a brake arrangement.

Special screw jack BSD and BSDL 40-71

BENZLER BS-Worm gears size 40 to 71 can be combined with trapezoidal lifting screw or ball screw with translating screw or lifting nut.

Capacities up to 30 kN (3 tonne)

Standard executions

BD Screw jack with translating lifting screw

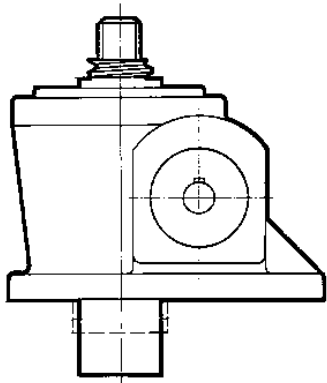

Fig. 2

BDL Screw jack with lifting nut

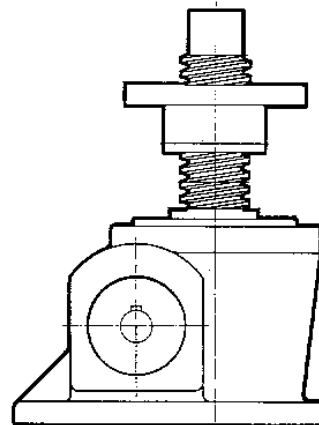

Fig. 3

Screw jack with PVC bellow

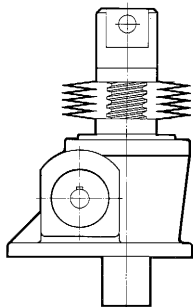

Fig. 4

Screw jack with motorflange

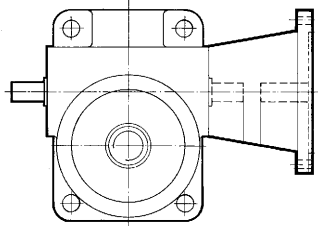

Fig. 5

SM Stop nut

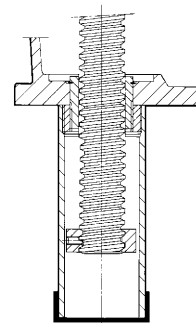

Fig. 6

Variant executions

BDK Ball screw jack with translating lifting screw

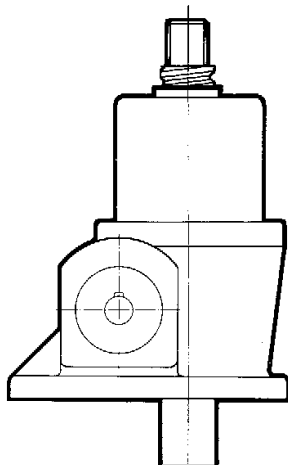

Fig. 7

BDKL Ball screw jack with lifting nut

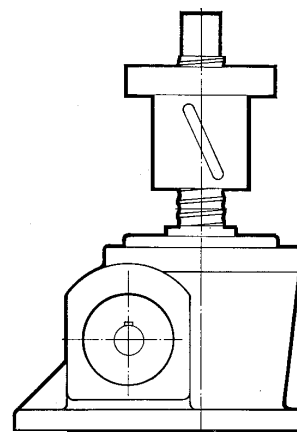

Fig. 8

Variant executions

LR Locked against rotation

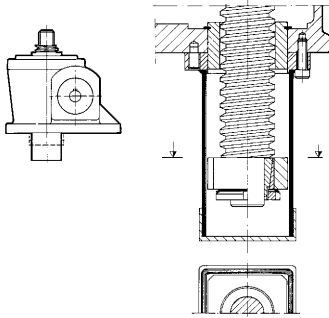

Fig. 9

LRK Locked against rotation with key

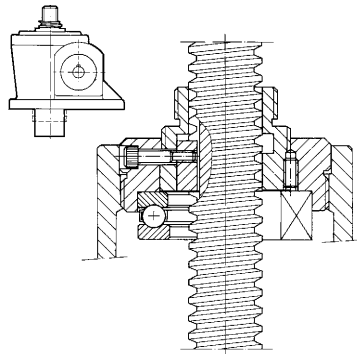

Fig. 10

ABL Antibacklash

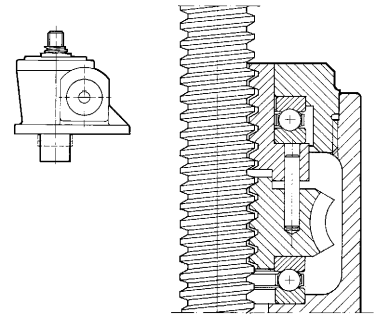

Fig. 11

LS Limit switches

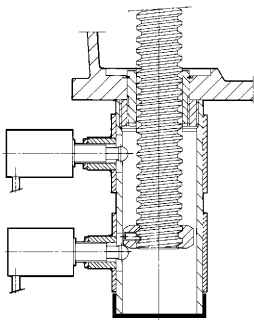

Fig. 12

SHM Safety nut

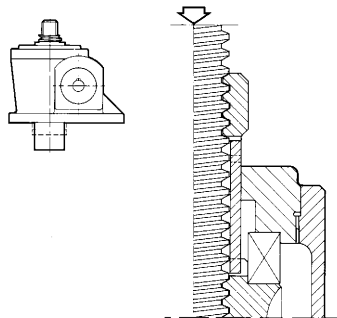

Fig. 13

Double Clevis Ends
(with reinforced protection tube)

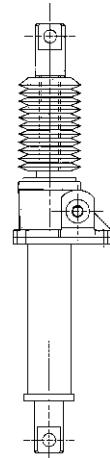

Fig. 14

Special executions

Worm gears BS 40-71 as screw jacks
BSD / BSDL / BSDKL

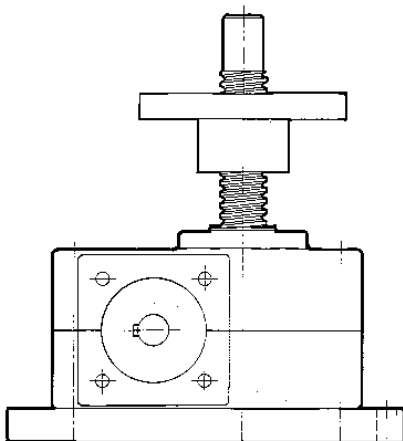

Fig. 15

Screw jack with worm gear motor

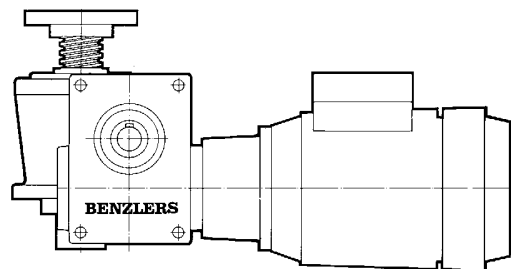

Fig. 16

Selection guide

SELECTION GUIDE

for the application of Benzlers Worm Gear Screw
Jacks

Name of company:

Address:

Telephone/Fax:

Contact person:

Describe the intended installation:
(a sketch is advisable)

Number of jacks per installation:

AXIAL LOAD ON LIFTING SCREW

Dynamic load per screw jack normal(kN):

Dynamic load per screw jack max(kN):

Static load per screw jack max (kN):

Type of load ?(pull/push/push and pull):

Vibrations ?(yes/no):

Shock loads?(yes/no):

Side loads? (yes/no):

ENVIRONMENT

Ambient temperature(°C): Outdoor use?:

Humidity:

Clean/Dusty/Oily/Greasy/Wet/Corrosive

Others, specify:

OPERATING CYCLE

Cycles / hour:

Hours / day:

Days / year:

LIFTING SCREW

Axially travelling screw or nut? (BD/BDL):

Stroke length(mm):

Lifting speed (mm/min):

Mounting position of screw(horizontal/upwards/inverted):

Ballscrew preferred?(yes/no):

Screw end (thread, top plate, clevis):

Protection bellow?(yes/no):

Protection tube on reverse side?(yes/no):

Stainless material:

OPTIONS

Safety nut SHM, state safety load direction:

Stop nut SM:

Locked against rotation with square tube LR:

Locked against rotation with a key LRK:

Anti backlash ABL:

Limit switch, state how many:

Stainless jackbody:

Stainless worm screw:

Stainless endfittings:

MOTORS

Motor flange (no, right mounted, left mounted):

Motor data (voltage, 50-60Hz, brake):

Determination of type

1. Type BD = Screw jack with translating screw
 Type BDL = Screw jack with travelling nut
 Type BDK = Ball screw jack with translating screw
 Type BDKL = Ball screw jack with travelling nut
2. Size = 27, 40, 58, 66, 86, 100, 125, 200
3. L = Low worm gear ratio with single start lifting screw
 H = High worm gear ratio with single start lifting screw
 L2 = Low worm gear ratio with double start lifting screw
 H2 = High worm gear ratio with double start lifting screw

4. Direction of lifting screw

- U = Upright
 N = Inverted

5. Lifting screw end execution

- 1 = Threaded end
 2 = Top plate
 3 = Clevis end
 4 = Special execution (Specify)
 R1 = Stainless lifting screw with threaded end
 R2 = Stainless lifting screw with topplate
 R3 = Stainless lifting screw with clevis end

6. Stroke

= mm

7. Bellows

- B = PVC bellow
 OB = Other bellows, specify in order

8. Options

- SHM = Safety nut, specify load safety direction
 SM = Stop nut
 LR = Locked against rotation
 LRK = Locked against rotation with key
 ABL = Antibacklash
 LS = 2 limit switches including stop nut

9. Stainless steel executions

- HR = Stainless gearhousing
 PR = Stainless worm screw
 PH = Stainless gearhousing and worm screw

10. Motorflange

- MCH = Motorflange right*
 MCV = Motorflange left*
 *State motorsize and flange

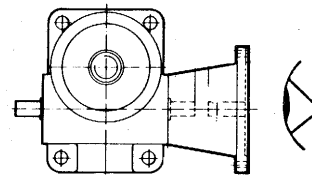

11. Motor/Gear unit

Example

1	2	3	4	5	6	7	8	9	10	11
BD	58	- L	- U	- 1	- 250	- B	- ABL/SM	- PH	- MCH	- 71/B14
Type	Size	Ratio	Direction	End execution	Stroke	Bellow	Additional devices	Stainless	Motorflange	Motor

Direction of rotation

Note: For types BD and BDK spindle must be held to prevent rotation. For types BDL and BDKL lifting nut must be held to prevent rotation.

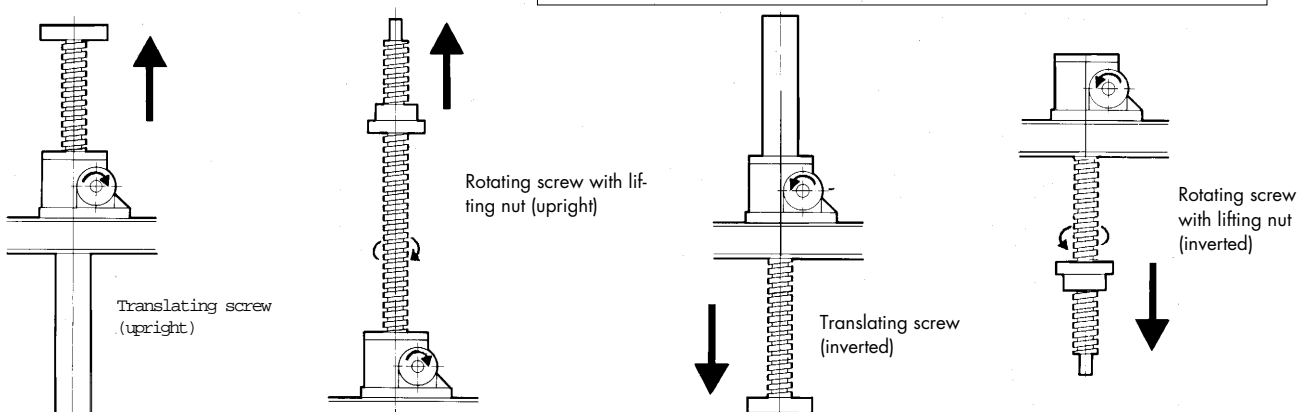

Fig. 17

Selection of jacks

Symbols used:

- F = Force (N) (1 tonne = 10 000 N)
- v = Lifting speed (mm/min)
- s = Pitch of lifting screw (mm)
- n = Required input speed (rpm)
- i = Ratio of worm gear set
- ED = Intermittence factor (%)
- P_d = Running power of screw jack (kW)
- P_s = Starting power of screw jack (kW)
- P_{ED} = Thermal power (kW)
- P_{Mnom} = Nominal motor power (kW)
- P_{Mst} = Starting power of motor (kW)
- P_{Max} = Max allowable input power of screw jack (kW)
- η_d = Running efficiency of screw jack
- η_s = Starting efficiency of screw jack

To calculate a screw jack you must at least know the force (F) to be moved and the lifting speed (v).

There are three types of standard format Benzler mechanical jacks.

I. BD/BDL

Screw jack with single start trapezoidal lifting screw available in 8 sizes, as standard.

This is the most frequently used screw jack, suitable for low lifting speeds (up to 2400 mm/min), competitively priced.

II BD/BDL

Screw jack with double start trapezoidal lifting screw available in 8 sizes, as standard.

Higher lifting speeds can be obtained, compared to single start lifting screw, with increased efficiency, a brake must be included in the system, as they are not self sustaining.

III BDK/BDKL

Screw jack with ball screw lifting screw, available in 4 sizes as variants. This type is suitable for high lifting speeds.

Owing to the higher overall efficiency, it is suited for applications with high degree of utilization required. (High ED).

Brake must be included in the system, as they are not self sustaining.

1. Select a screw jack where the nominal force is larger than the required force. (See "Technical data").
2. By compression load check stroke length for bending according to Euler I, II or III (See compression load tables)
3. Check in Power rating tables that the max allowable power or torque is not exceeded.
4. Selection of one screw jack
Calculate the running power (P_d) and starting power (P_s). P_d is stated in tables, see note 3 or calculate as follows

$$P_d = \frac{F \times v}{\eta_d \times 6 \times 10^7}$$

$$P_s = \frac{F \times v}{\eta_s \times 6 \times 10^7}$$

η_d = running efficiency (see "Power rating tables")

η_s = starting efficiency (see "Technical data")

5. State the intermittence factor
ED in %/hour
Example: 12 min/hour = 20%
6. If ED is other than 20% check on page 23 or 38 that the thermal power P_{ED} is not exceeded.
The selection of jack is correct if P_{ED} > P_d (P_d see note 4).
7. When selecting screw jack type BDL and BDKL check critical spindle speed, see page 24 or 38.
8. Only screw jacks type BD can permit side forces (see table page 25).
9. Selection of motor:
 - I Check that
Nominal motor power P_{Mnom} > P_d (P_d, see note 4)
 - II Check that
Starting power of motor P_{Mst} > P_s (P_s, see note 4)

To determine the starting power of motor, following formula is used in most cases:

$$P_{Mst} = \frac{M_{st}}{M} \times P_{Mnom}$$

$\frac{M_{st}}{M}$ = factor stated in motor catalogue

Note: For three phase motor the factor $\frac{M_{st}}{M}$ is normally 1.8 - 2.5.

Consult BENZLERS for further information

10. Calculate the required input speed

$$n = \frac{v \times i}{s} \text{ (rpm)}$$

(i and s, see Technical data)

Calculation of multi jack arrangement

To calculate a screw jack arrangement is described in a simplified way below. For a more detailed calculation consult Benzlers.

- 1) Calculate the power consumption of each single jack in the arrangement as under "4" for single Jacks.
- 2) Add the power consumption of each single jack to get the total power consumption, P_x.
- 3) Attention must be paid to the efficiency of the connecting shaft system and other components in the arrangement such as: Worm Gears, Bevel Gears, Helical Gears, Couplings, Bearings and normal misalignment when mounting the arrangement.
If this is not possible use the following arrangement efficiency:

Number of jacks	η _{arr}
2	0,95
3	0,90
4	0,85
6-8	0,80

$$P_{arr} = \frac{P_x}{\eta_{arr}}$$

P_{arr} = Total power consumption of the arrangement

P_x = The sum of the power consumption each single jack

η_{arr} = The efficiency of the arrangement acc to table

- 4) After calculating design motor power required, care should be taken to choose a larger motor with a safe working margin of excess power.
- 5) By high lifting speeds and high speed in connecting shaft system, the mass-moment of inertia must be taken into consideration.

Description of BD - BDL

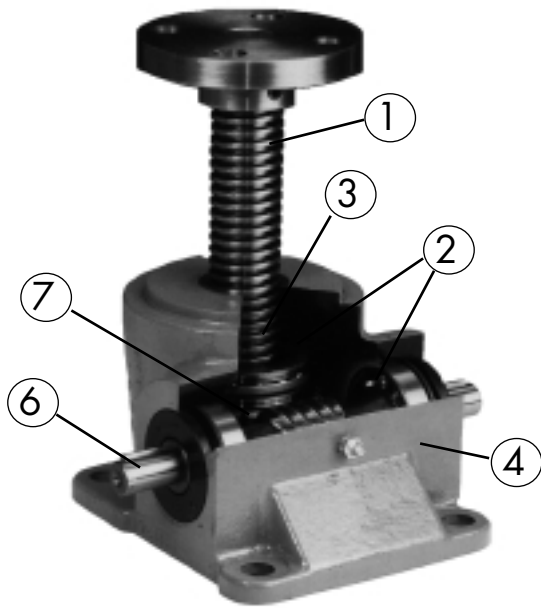

- 1 Trapezoidal lifting screw
- 2 Thrust and radial bearings
- 3 Grease of EP-quality
- 4 Housing of nodular cast iron
- 5 Alkyd paint 85 micron thick in RAL 5015
- 6 Worm screw hardened and ground
- 7 Worm wheel of centrifugally cast tin bronze
- 8 Bellows in PVC, steel or other materials.

Benzlers mechanical jacks have a allowable working temperature range from -30°C to $+100^{\circ}\text{C}$. At full load the degree of utilization (ED) must not normally exceed 40% per 10 minutes, still not more than 20% per hour totally, in valid at ambient temperature $+25^{\circ}\text{C}$.

For other conditions consult Benzlers.

Technical data, single start spindle

Type	27	40	58	66	86	100	125	200
Max capacity N	10000	25000	50000	150000	200000	300000	500000	1000000
Lifting screw	Tr 20x4	Tr 30x6	Tr 40x7	Tr 55x9	Tr 65x10	Tr 90x12	Tr120x14	Tr160x16
Ratio (L)	9:1	7:1	6.75:1	7:1	7:1	7:1	7.5:1	12:1
Raise per revolution (mm)	0.444	0.857	1.037	1.285	1.428	1.714	1.866	1.333
Starting torque/Handwind torque at max load (Nm)	6	23	55	210	320	640	1280	2235
Max running power at 20% ED (kW)	0.2	0.55	0.9	1.5	2.9	3.7	5.1	12.5
Starting efficiency η_s	0.12	0.15	0.14	0.14	0.14	0.12	0.11	0.09
Ratio (H)	27:1	30:1	27:1	28:1	28:1	28:1	30:1	36:1
Raise per revolution (mm)	0.148	0.200	0.259	0.321	0.357	0.428	0.466	0.444
Starting torque/Handwind torque at max load (Nm)	5	10	32	115	160	320	640	1335
Max running power at 20% ED (kW)	0.15	0.5	0.8	1.3	2.6	3.3	4.5	12
Starting efficiency η_s	0.05	0.08	0.06	0.06	0.07	0.06	0.05	0.05
Start torque on lifting screw at max load	21	77	199	810	1261	2548	5535	14425
Running efficiency η_d	See Power ratings BD - BDL							
Weight without spindle or protection tube BD/BDL (kg)	2/2.4	7/8	14/16.5	22/25	41/49	73/85	134/162	450
Weight of lifting screw 100 mm (kg)	0.2	0.45	0.82	1.6	2.2	4.4	7.9	14
Normal axial backlash (mm)	0.1-0.25	0.1-0.30	0.1-0.35	0.1-0.40	0.1-0.40	0.1-0.40	0.1-0.45	

(Antibacklash see Options)

Technical data, double start spindle

Size	27	40	58	66	86	100	125	200
Max capacity N	8000	20000	40000	120000	160000	240000	400000	800000
Lifting screw	Tr 20x8	Tr 30x12	Tr 40x14	Tr 55x18	Tr 65x20	Tr 90x24	Tr120x28	Tr160x32
Ratio (L)	9:1	7:1	6.75:1	7:1	7:1	7:1	7.5:1	12:1
Raise per revolution (mm)	0.888	1.714	2.074	2.571	2.857	3.428	3.733	2.667
Starting torque/Handwind torque at max load (Nm)	6	23	55	210	320	640	1280	2120
Max running power at 20% ED (kW)	0.25	0.7	1.1	1.9	3.6	4.7	6.4	16.0
Starting efficiency	0.18	0.23	0.23	0.22	0.22	0.20	0.19	0.16
Ratio (H)	27:1	30:1	27:1	28:1	28:1	28:1	30:1	36:1
Raise per revolution (mm)	0.296	0.400	0.518	0.642	0.714	0.856	0.932	0.889
Starting torque/Handwind torque at max load (Nm)	4.8	10.1	32.5	117	164	323	624	1265
Max running power at 20% ED (kW)	0.20	0.60	1.0	1.6	3.2	4.1	5.6	15.0
Starting efficiency	0.07	0.12	0.10	0.10	0.11	0.10	0.09	0.08
Start torque on lifting screw at max load	22	82	206	648	1276	2518	5358	13660
Running efficiency	See Power ratings BD - BDL							
*Holding torque Nm	0.35	1.8	5.5	16	24	44	80	115
Weight without spindle or protection tube BD/BDL (kg)	2/2.4	7/8	14/16.5	22/25	41/49	73/85	134/162	450
Weight of lifting screw 100 mm (kg)	0.2	0.45	0.82	1.6	2.2	4.4	7.9	14
Normal axial backlash (mm)	0.1-0.25 0.15-0.45	0.1-0.30 0.15-0.50	0.1-0.35	0.1-0.40	0.1-0.40	0.1-0.40	0.1-0.45	

*) The holding torque is the torque on the input shaft which is required to prevent the load from being lowered.

Technical data, static load

Maximum allowed static load [kN] (at tension loads in lifting screw)

Size	27	40	58	66	86	100	125	200
Dynamic capacity	10	25	50	150	200	300	500	1000
BD, static	19,5	52,5	117,5	180	255	474	900	1320
BDL, static	17,5	41	88	180	240	300	500	1000

Above values can be allowed when the load is still. Under movement or when vibrations can occur are the dynamic values valid. At all cases with compression load must not the values in the "compression load table BD - BDL" be exceeded.

Compression load table BD-BDL Load case I

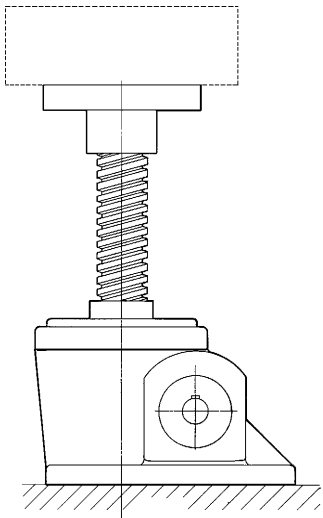
Size	27	40	58	66	86	100	125	200	
Max capacity (kN)	10	25	50	150	200	300	500	1000	
<p>Max capacity, compression load (kN) for different lengths of stroke at threefold safetyfactor against breaking (Euler I)</p> <p style="text-align: center;"><i>Free load</i></p>  <p style="text-align: center;">Fig. 18</p>	0.2								
	0.3	5.4							
	0.4	(3.1)	15						
	0.5		9.5	36	139				
	0.6		(6.6)	25	96				
	0.7		(4.8)	18	71	147			
	0.8			14	54	112			
	0.9			(11)	43	89			
	1.0			(8.9)	35	72	298		
	1.25				(22)	46	190		
	1.5					(32)	132	440	
	1.75						97	323	
	2.0						(74)	248	860
	2.25						(59)	196	680
	2.5							158	551
	2.75							(131)	455
	3.0							(110)	382
	3.25							(94)	326
	3.5								281
	3.75								(245)
	4.0								(215)
	4.25								(191)
	4.5								
	4.75								
	5.0								
5.5									
6.0									
6.5									
7.0									
7.5									
8.0									

The values given in brackets must only be used at low lifting speed and concentric load on the lifting screws.

Compression load table BD-BDL Load case II

Size	27	40	58	66	86	100	125	200
Max capacity (kN)	10	25	50	150	200	300	500	1000
<p>Max capacity, compression load (kN) for different lengths of stroke at three-fold safetyfactor against breaking (Euler II)</p> 	0.2							
	0.3							
	0.4							
	0.5	7.8						
	0.6	5.4						
	0.7	4.0	19					
	0.8	(3.1)	15					
	0.9	(2.4)	12	44				
	1.0		9.5	36	139			
	1.25		(6.1)	23	89	184		
	1.5			16	62	128		
	1.75			(12)	45	94		
	2.0				35	72	298	
	2.25				27	57	235	
	2.5				(22)	46	190	
	2.75				(18)	(38)	157	
	3.0					(32)	132	440
	3.25					(27)	113	375
	3.5						97	323
	3.75						85	282
4.0						(74)	248	860
4.25						(66)	219	762
4.5						(59)	196	680
4.75							176	610
5.0							158	551
5.5							(131)	455
6.0							(110)	382
6.5							(94)	326
7.0								281
7.5								(245)
8.0								(215)

Fig. 19

The values given in brackets must only be used at low lifting speed and concentric load on the lifting screws.

Compression load table BD-BDL Load case III

Size	27	40	58	66	86	100	125	200
Max capacity (kN)	10	25	50	150	200	300	500	1000
<p>Max capacity, compression load (kN) for different lengths of stroke at three-fold safetyfactor against breaking (Euler III)</p> <p><i>Supported spindle</i></p>  <p><i>Guided load</i></p> 	0.2							
	0.3							
	0.4							
	0.5							
	0.6							
	0.7	8.0						
	0.8	6.1						
	0.9	4.8	23					
	1.0	3.9	19					
	1.25	(2.5)	12	45				
	1.5		8.4	32	123			
	1.75		(6.2)	23	91	188		
	2.0		(4.7)	18	69	144		
	2.25			14	55	114		
	2.5			(11)	44	92		
	2.75			(9.4)	37	76		
	3.0				31	64	265	
	3.25				(26)	55	225	
	3.5				(23)	47	194	
	3.75				(20)	41	169	
4.0				(17)	(36)	149	495	
4.25					(32)	132	439	
4.5					(28)	118	391	
4.75					(25)	105	351	
5.0						95	317	
5.5						79	262	910
6.0						(66)	220	765
6.5						(56)	188	652
7.0							162	562
7.5							(141)	490
8.0							(124)	430

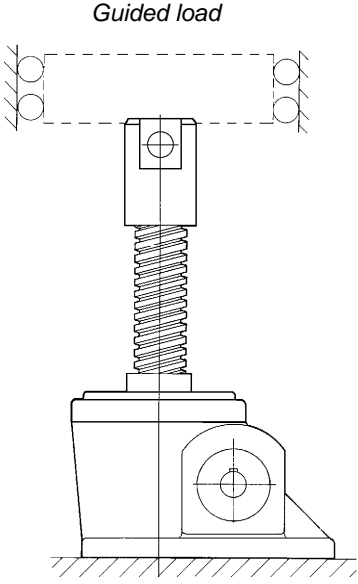
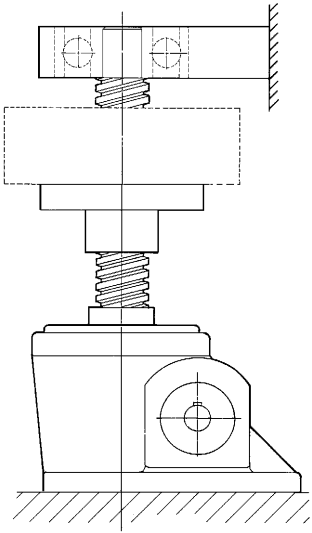
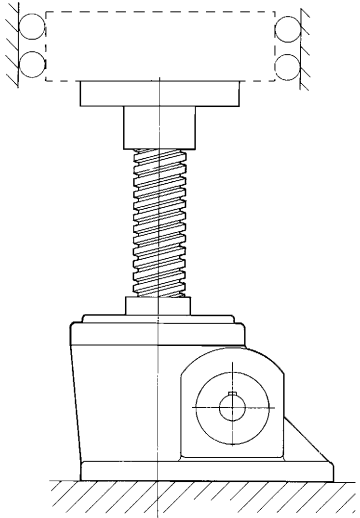
The values given in brackets must only be used at low lifting speed and concentric load on the lifting screws.

Power ratings BD-BDL

Power ratings for BD-BDL with single start spindle at 40% ED/10 min or max 20% ED/hour at ambient temperature +25° C.

- n = input speed (rpm)
- v = lifting speed (mm/min)
- η_d = running efficiency
- L = low ratio
- H = high ratio
- T = input torque (Nm)
- P = input power (kW)
- i = ratio of worm gear set

Mechanical and Thermal capacities:

- A) Mechanical capacity = all stated values non blank areas in tables.
- B) Mechanical capacity with stainless worm screw: (Grey areas in tables)
- C) Thermal capacity:
The figures above the line in italic style can only be used at ED lower than 20%. Thermal power must be checked. See "Intermittance factor (ED) BD/BDL".

Note: Power ratings indicate running power. Additional power will be required on start. See "Selection of jacks".

BD 27 L (i = 9) H (i = 27) TR 20 x 4 (Single start)

n rpm	v mm/min		η_d		10 kN				8 kN				6 kN				4 kN					
	L	H	L	H	T	L	P	T	H	P	T	L	P	T	H	P	T	L	P	T	H	P
					Nm	kW	Nm	kW	Nm	kW	Nm	kW	Nm	kW	Nm	kW	Nm	kW	Nm	kW	Nm	kW
2900	1289	430	.31	.18	2.2	.68	1.3	.38	1.8	.56	1.1	.32	1.4	.44	.88	.26	1.0	.32	.66	.20		
1750	778	259	.29	.16	2.4	.44	1.4	.25	2.0	.36	1.2	.21	1.5	.28	.94	.17	1.1	.20	.70	.13		
1500	667	222	.28	.16	2.5	.39	1.4	.22	2.0	.32	1.2	.18	1.6	.25	.94	.15	1.1	.18	.70	.11		
1000	444	148	.26	.15	2.7	.28	1.5	.16	2.2	.23	1.2	.13	1.7	.18	1.0	.11	1.2	.13	.74	.08		
750	333	111	.25	.14	2.8	.22	1.6	.13	2.3	.18	1.3	.11	1.8	.14	1.1	.09	1.3	.10	.78	.06		
500	222	74	.23	.13	3.0	.16	1.8	.09	2.4	.13	1.5	.07	1.9	.10	1.2	.06	1.3	.07	.86	.05		
400	178	59	.22	.12	3.1	.13	1.9	.08	2.5	.11	1.6	.07	2.0	.08	1.2	.05	1.4	.06	.90	.05		
300	133	44	.21	.11	3.2	.10	2.0	.06	2.6	.08	1.6	.05	2.0	.06	1.3	.05	1.4	.05	.94	.05		
200	89	30	.20	.10	3.4	.07	2.2	.05	2.8	.06	1.8	.05	2.1	.05	1.4	.05	1.5	.05	1.0	.05		
100	44	15	.18	.09	3.8	.05			3.1	.05	2.0	.05	2.4	.05	1.6	.05	1.7	.05	1.1	.05		
50	22	7	.17	.08					3.3	.05	2.3	.05	2.6	.05	1.8	.05	1.8	.05	1.3	.05		

n rpm	v mm/min		η_d		2 kN				1 kN							
	L	H	L	H	T	L	P	T	H	P	T	L	P	T	H	P
					Nm	kW	Nm	kW	Nm	kW	Nm	kW	Nm	kW	Nm	kW
2900	1289	430	.31	.18	.63	.19	.45	.13	.44	.13	.35	.10				
1750	778	259	.29	.16	.67	.12	.47	.09	.46	.08	.36	.06				
1500	667	222	.28	.16	.69	.11	.47	.07	.47	.07	.36	.06				
1000	444	148	.26	.15	.73	.08	.49	.05	.49	.05	.37	.05				
750	333	111	.25	.14	.75	.06	.51	.05	.50	.05	.38	.05				
500	222	74	.23	.15	.79	.05	.55	.05	.52	.05	.40	.05				
400	178	59	.22	.12	.81	.05	.57	.05	.55	.05	.41	.05				
300	133	44	.21	.11	.85	.05	.59	.05	.54	.05	.42	.05				
200	89	30	.20	.10	.87	.05	.63	.05	.56	.05	.44	.05				
100	44	15	.18	.09	.95	.05	.69	.05	.60	.05	.47	.05				
50	22	7	.17	.08	1.0	.05	.75	.05	.63	.05	.50	.05				

BD 40 L (i = 7) H (i = 30) TR 30 x 6 (Single start)

n rpm	v mm/min		η _d		25 kN				20 kN				15 kN				10 kN						
	L	H	L	H	T	L	P	T	H	P	T	L	P	T	H	P	T	L	P	T	H	P	
					Nm	kW		Nm	kW		Nm	kW	Nm	kW		Nm	kW	Nm	kW	Nm	kW	Nm	kW
2600	2229		.38		8.9	2.4					7.2	1.9				5.5	1.5					3.8	1.0
1750	1500	350	.36	.22	9.4	1.7	3.5	.64	7.6	1.4	2.9	.52	5.8	1.0	2.2	.41	4.0	.72	1.6	.29			
1500	1286	300	.35	.22	9.6	1.5	3.6	.56	7.7	1.2	2.9	.46	5.9	.92	2.3	.36	4.0	.63	1.6	.26			
1000	857	200	.33	.20	10	1.1	3.9	.40	8.3	.89	3.2	.33	6.3	.67	2.5	.25	4.3	.46	1.8	.18			
750	643	150	.31	.19	11	.84	4.1	.32	8.7	.68	3.3	.26	6.6	.51	2.6	.20	4.5	.35	1.8	.14			
500	429	100	.29	.18	12	.60	4.4	.23	9.3	.48	3.6	.19	7.0	.37	2.8	.15	4.8	.25	2.0	.01			
400	343	80	.28	.17	12	.50	4.6	.19	9.6	.40	3.7	.15	7.3	.31	2.9	.12	5.0	.21	2.0	.08			
300	257	60	.27	.16	13	.39	4.8	.15	10	.31	3.9	.12	7.6	.24	3.0	.09	5.2	.16	2.1	.07			
200	171	40	.25	.15	13	.28	5.2	.11	11	.23	4.2	.09	8.1	.17	3.3	.07	5.5	.12	2.3	.05			
100	86	20	.23	.13	15	.15	5.8	.06	12	.12	4.7	.05	9.0	.09	3.6	.05	6.1	.06	2.5	.05			
50	43	10	.21	.12	16	.08	6.5	.05	12	.06	5.3	.05	9.8	.05	4.0	.05	6.6	.05	2.8	.05			

n rpm	v mm/min		η _d		7.5 kN				5 kN				2.5 kN			
	L	H	L	H	T	L	P	T	H	P	T	L	P	T	H	P
					Nm	kW		Nm	kW		Nm	kW	Nm	kW	Nm	kW
2600	2229		.38	.24	2.9	.79					2.1	.55			1.2	.32
1750	1500	350	.36	.22	3.1	.55	1.3	.24	2.2	.39	.98	.18	1.2	.23	.66	.12
1500	1286	300	.35	.22	3.1	.49	1.3	.21	2.2	.34	1.0	.16	1.3	.20	.67	.10
1000	857	200	.33	.20	3.3	.36	1.4	.15	2.3	.25	1.1	.11	1.3	.14	.70	.07
750	643	150	.31	.19	3.5	.27	1.5	.11	2.4	.19	1.1	.09	1.4	.11	.72	.06
500	429	100	.29	.18	3.7	.19	1.6	.08	2.6	.13	1.2	.06	1.5	.08	.75	.05
400	343	80	.28	.17	3.8	.16	1.6	.07	2.7	.11	1.2	.05	1.5	.06	.77	.05
300	257	60	.27	.16	4.0	.12	1.7	.05	2.8	.09	1.2	.05	1.6	.05	.79	.05
200	171	40	.25	.15	4.2	.09	1.8	.05	2.9	.06	1.3	.05	1.6	.05	.83	.05
100	86	20	.23	.13	4.7	.05	2.0	.05	3.2	.05	1.4	.05	1.8	.05	.89	.05
50	43	10	.21	.12	5.1	.05	2.2	.05	3.5	.05	1.6	.05	1.9	.05	.96	.05

BD 58 L (i = 6.75) H (i = 27) TR 40 x 7 (Single start)

n rpm	v mm/min		η _d		50 kN				40 kN				30 kN				25 kN					
	L	H	L	H	T	L	P	T	H	P	T	L	P	T	H	P	T	L	P	T	H	P
					Nm	kW		Nm	kW		Nm	kW	Nm	kW	Nm	kW	Nm	kW	Nm	kW	Nm	kW
2000	2074		.36	.21									14	2.8			11	2.4				
1750	1815	454	.35	.22			9.0	1.7			7.3	1.4	14	2.5	5.6	1.1	12	2.1	4.8	.90		
1500	1556	389	.35	.22			9.3	1.5			7.5	1.2	14	2.2	5.8	.93	12	1.8	4.9	.79		
1000	1037	259	.33	.20			10	1.1	20	2.1	8.2	.89	15	1.6	6.3	.68	13	1.3	5.3	.58		
750	778	194	.31	.19			11	.84	21	1.6	8.7	.68	16	1.2	6.6	.53	13	1.0	5.6	.44		
500	519	130	.29	.17	28	1.5	12	.61	22	1.2	9.5	.49	17	.91	7.2	.38	14	.76	6.1	.32		
400	415	104	.28	.16	29	1.2	12	.51	23	.96	9.9	.41	17	.73	7.5	.31	15	.61	6.4	.27		
300	311	78	.27	.15	30	.95	13	.41	24	.76	11	.33	18	.58	8.0	.25	15	.48	6.8	.21		
200	207	52	.25	.14	32	.67	14	.30	26	.54	11	.24	19	.41	8.7	.18	16	.34	7.4	.16		
100	104	26	.23	.12	36	.37	16	.17	29	.30	13	.14	22	.22	10	.10	18	.19	8.4	.09		
50	52	13	.21	.11	39	.21	19	.10	31	.17	15	.08	24	.13	11	.06	20	.11	9.5	.05		

n rpm	v mm/min		η _d		20 kN				15 kN				10 kN			
	L	H	L	H	T	L	P	T	H	P	T	L	P	T	H	P
					Nm	kW		Nm	kW		Nm	kW	Nm	kW	Nm	kW
2000	2074		.36	.21	9.2	1.9					7.0	1.5	4.8	1.0		
1750	1815	454	.35	.22	9.4	1.7	3.9	.74	7.2	1.3	3.1	.58	4.9	.90	2.2	.42
1500	1556	389	.35	.22	9.6	1.5	4.0	.65	7.3	1.1	3.2	.51	5.0	.79	2.3	.36
1000	1037	259	.33	.20	10	1.1	4.3	.47	7.7	.82	3.4	.37	5.3	.57	2.4	.26
750	778	194	.31	.19	11	.82	4.6	.36	8.1	.63	3.6	.28	5.6	.43	2.6	.20
500	519	130	.29	.17	11	.62	5.0	.26	8.6	.47	3.9	.20	5.9	.32	2.8	.14
400	415	104	.28	.16	12	.49	5.2	.22	9.0	.38	4.0	.17	6.2	.26	2.9	.12
300	311	78	.27	.15	12	.39	5.5	.17	9.4	.30	4.3	.13	6.4	.20	3.0	.09
200	207	52	.25	.14	13	.27	6.0	.13	10	.21	4.6	.10	6.8	.14	3.3	.07
100	104	26	.23	.12	15	.15	6.8	.07	11	.11	5.3	.05	7.6	.08	3.7	.05
50	52	13	.21	.11	16	.09	7.7	.05	12	.06	5.9	.05	8.3	.05	4.1	.05

BD 66 L (i = 7) H (i = 28) TR 55 x 9 (Single start)

n rpm	v mm/min		η_d		150 kN				125 kN				100 kN				75 kN							
	L	H	L	H	T	L	P	T	H	P	T	L	P	T	H	P	T	L	P	T	H	P		
					Nm	kW	Nm	kW	Nm	kW	Nm	kW	Nm	kW	Nm	kW	Nm	kW	Nm	kW	Nm	kW		
1750	2250	563	.36	.23																		16	3.0	
1500	1929	482	.35	.23																			17	2.6
1000	1286	321	.33	.21																			18	1.9
750	964	241	.32	.19																		48	3.7	
500	643	161	.31	.18																		51	2.7	
300	386	96	.27	.16																		28	1.5	
250	321	80	.26	.15																		74	2.3	
200	257	64	.25	.15																		31	.98	
150	193	48	.24	.14																		56	1.7	
125	161	40	.23	.13																		57	1.5	
100	129	32	.23	.13	133	1.4																60	1.3	
50	64	16	.20	.11	146	.77	67	.35														76	2.0	
																							79	1.7
																							83	1.3
																							85	1.1
																							89	.94
																							98	.51
																							45	.23

n rpm	v mm/min		η_d		50 kN				25 kN				20 kN				10 kN					
	L	H	L	H	T	L	P	T	H	P	T	L	P	T	H	P	T	L	P	T	H	P
					Nm	kW	Nm	kW	Nm	kW	Nm	kW	Nm	kW	Nm	kW	Nm	kW	Nm	kW	Nm	kW
1750	2250	563	.36	.23	28	5.1	11	2.0	14	2.6	5.8	1.1	12	2.1	4.8	.88	6.1	1.1	2.7	.50		
1500	1929	482	.35	.23	29	4.5	11	1.8	15	2.3	6.0	.93	12	1.9	4.9	.76	6.2	.98	2.7	.43		
1000	1286	321	.33	.21	30	3.2	12	1.3	16	1.6	6.4	.68	13	1.3	5.3	.55	6.6	.69	2.9	.31		
750	964	241	.32	.19	32	2.5	13	1.0	16	1.3	6.8	.53	13	1.0	5.6	.43	6.9	.54	3.1	.24		
500	643	161	.31	.18	34	1.8	14	.77	17	.92	7.4	.40	14	.74	6.1	.33	7.3	.38	3.3	.17		
300	386	96	.27	.16	37	1.2	16	.50	19	.59	8.3	.26	15	.48	6.7	.21	7.9	.25	3.7	.11		
250	321	80	.26	.15	38	1.0	17	.43	20	.51	8.6	.22	16	.41	7.0	.18	8.2	.21	3.8	.10		
200	257	64	.25	.15	40	.86	17	.36	20	.43	9.0	.19	16	.35	7.3	.15	8.5	.18	3.9	.08		
150	193	48	.24	.14	42	.65	18	.29	21	.33	9.5	.15	17	.26	7.7	.12	8.8	.14	4.2	.07		
125	161	40	.23	.13	43	.56	19	.25	22	.29	9.8	.13	18	.23	8.0	.10	9.1	.12	4.3	.06		
100	129	32	.23	.13	45	.47	20	.21	23	.24	10	.11	18	.19	8.3	.09	9.4	.10	4.5	.05		
50	64	16	.20	.11	49	.26	23	.12	25	.13	12	.06	20	.11	9.4	.05	10	.05	5.0	.05		

BD 86 L (i = 7) H (i = 28) TR 65 x 10 (Single start)

n rpm	v mm/min		η_d		200 kN				160 kN				120 kN				100 kN							
	L	H	L	H	T	L	P	T	H	P	T	L	P	T	H	P	T	L	P	T	H	P		
					Nm	kW	Nm	kW	Nm	kW	Nm	kW	Nm	kW	Nm	kW	Nm	kW	Nm	kW	Nm	kW		
1500	2143	536	.35	.23																			29	4.5
1000	1429	357	.33	.22																			31	3.2
750	1071	268	.32	.20																			67	7.0
500	714	179	.30	.19																			70	5.5
300	429	107	.27	.17																			28	2.2
250	357	89	.26	.16																			75	3.9
200	286	71	.25	.15																			30	1.6
150	214	54	.24	.14																			82	2.6
125	179	45	.23	.14	184	2.9	76	1.2	131	4.1	53	1.7	98	3.1	40	1.3	82	2.6	34	1.1				
100	143	36	.23	.13	190	2.5	79	1.0	135	3.5	55	1.4	102	2.6	42	1.1	85	2.2	35	.91				
50	71	18	.20	.12	197	2.1	83	.87	141	2.9	58	1.2	106	2.2	44	.91	88	1.8	36	.76				
					218	1.1	94	.49	147	2.3	61	.96	111	1.7	46	.73	92	1.5	39	.61				
									152	2.0	64	.80	114	1.5	48	.60	95	1.3	40	.51				
									157	1.7	67	.70	118	1.3	50	.53	99	1.1	42	.44				
									174	.88	76	.39	131	.66	57	.30	109	.55	48	.25				

n rpm	v mm/min		η_d		75 kN				50 kN				25 kN									
	L	H	L	H	T	L	P	T	H	P	T	L	P	T	H	P	T	L	P	T	H	P
					Nm	kW	Nm	kW	Nm	kW	Nm	kW	Nm	kW	Nm	kW	Nm	kW	Nm	kW	Nm	kW
1500	2143	536	.35	.23	47	7.5	18	2.9	32	5.0	12	2.0	16	2.6	6.7	1.0						
1000	1429	357	.33	.22	50	5.3	20	2.1	34	3.5	13	1.4	17	1.8	7.2	.75						
750	1071	268	.32	.20	53	4.2	21	1.6	36	2.8	14	1.1	18	1.4	7.6	.59						
500	714	179	.30	.19	57	3.0	23	1.2	38	2.0	15	.81	19	1.0	8.2	.43						
300	429	107	.27	.17	62	1.9	25	.80	42	1.3	17	.55	21	.66	9.0	.29						
250	357	89	.26	.16	64	1.7	26	.69	43	1.1	18	.47	22	.57	9.3	.24						
200	286	71	.25	.15	66	1.4	28	.57	44	.92	19	.39	23	.47	9.8	.20						
150	214	54	.24	.14	70	1.1	29	.46	47	.74	20	.31	24	.37	10	.16						
125	179	45	.23	.14	72	.94	30	.38	48	.63	20	.26	24	.32	11	.13						
100	143	36	.23	.13	74	.79	32	.33	50	.53	21	.22	25	.27	11	.12						
50	71	18	.20	.12	82	.42	36	.19	55	.28	24	.13	28	.14	13	.07						

BD 100 L (i = 7) H (i = 28) TR 90 x 12 (Single start)

n rpm	v mm/min		η _d		300 kN				250 kN				200 kN				150 kN					
	L	H	L	H	T	L	P	T	H	P	T	L	P	T	H	P	T	L	P	T	H	P
					Nm	kW		Nm	kW		Nm	kW	Nm	kW	Nm	kW	Nm	kW	Nm	kW	Nm	kW
1000	1714	429	.32	.21															125	13	49	5.1
750	1286	321	.31	.19															131	10	52	4.1
500	857	214	.29	.18									187	9.8	69	5.4	141	7.4			56	2.9
300	514	129	.26	.16									206	6.5	84	2.6	155	4.9			63	2.0
250	429	107	.25	.15							266	7.0	109	2.9	213	5.6	87	2.3	160	4.2	66	1.8
200	343	86	.24	.14							277	5.8	115	2.4	222	4.6	92	1.9	166	3.5	69	1.4
150	257	64	.23	.13	350	5.5					291	4.6	122	1.9	233	3.7	98	1.5	175	2.8	74	1.1
125	214	54	.22	.13	361	4.7					301	3.9	127	1.7	241	3.1	102	1.4	181	2.4	77	1.0
100	171	43	.21	.12	375	3.9					313	3.3	133	1.4	250	2.6	107	1.1	188	2.0	80	.84
50	86	21	.19	.11	420	2.2	183	.96	350	1.8	153	.80	280	1.5	122	.64	210	1.1	92	.48		

n rpm	v mm/min		η _d		100 kN				75 kN				50 kN			
	L	H	L	H	T	L	P	T	H	P	T	L	P	T	H	P
					Nm	kW		Nm	kW		Nm	kW	Nm	kW	Nm	kW
1000	1714	429	.32	.21	84	8.7	33	3.4	63	6.6	25	2.6	42	4.4	17	1.8
750	1286	321	.31	.19	88	6.7	35	2.7	66	5.0	26	2.1	44	3.4	18	1.4
500	857	214	.29	.18	94	4.9	38	2.0	71	3.7	29	1.5	48	2.5	20	1.0
300	514	129	.26	.16	103	3.3	43	1.3	78	2.5	32	1.0	52	1.6	22	.67
250	429	107	.25	.15	107	2.8	44	1.2	80	2.1	33	.89	54	1.4	23	.60
200	343	86	.24	.14	111	2.3	47	.97	84	1.8	35	.74	56	1.2	24	.50
150	257	64	.23	.13	117	1.8	49	.77	88	1.4	37	.58	59	.93	25	.39
125	214	54	.22	.13	121	1.6	51	.69	91	1.2	39	.52	61	.79	26	.35
100	171	43	.21	.12	126	1.3	54	.57	95	.98	41	.43	63	.66	27	.29
50	86	21	.19	.11	141	.74	62	.32	106	.55	47	.24	71	.37	31	.16

BD 125 L (i = 7.5) H (i = 30) TR 120 x 14 (Single start)

n rpm	v mm/min		η _d		500 kN				400 kN				300 kN				250 kN					
	L	H	L	H	T	L	P	T	H	P	T	L	P	T	H	P	T	L	P	T	H	P
					Nm	kW		Nm	kW		Nm	kW	Nm	kW	Nm	kW	Nm	kW	Nm	kW	Nm	kW
1000	1867	467	.31	.20																	91	9.6
750	1400	350	.29	.19																	249	20.0
500	933	233	.27	.17									321	17	117	9.2	268	14.0	107	5.6		
300	560	140	.25	.15									354	11	144	4.5	295	9.2	120	3.8		
250	467	117	.24	.14									366	9.6	150	3.9	305	8.0	125	3.3		
200	373	93	.23	.14									509	11	158	3.3	318	6.9	131	2.8		
150	280	70	.22	.13									537	8.4	224	3.5	403	6.3	140	2.2		
125	233	58	.21	.12									556	7.3	233	3.1	417	5.5	145	1.9		
100	187	47	.20	.12	723	7.6			579	6.1	244	2.6	435	4.6	184	2.0	362	3.8	153	1.6		
50	93	23	.18	.10	815	4.3			652	3.4	281	1.5	489	2.6	211	1.1	408	2.2	176	.94		

n rpm	v mm/min		η _d		200 kN				150 kN				100 kN			
	L	H	L	H	T	L	P	T	H	P	T	L	P	T	H	P
					Nm	kW		Nm	kW		Nm	kW	Nm	kW	Nm	kW
1000	1867	467	.31	.20	190	20	73	7.7	143	15	55	5.8	96	10	37	3.9
750	1400	350	.29	.19	200	16	78	6.2	150	12	59	4.7	101	8.1	40	3.1
500	933	233	.27	.17	215	11.0	86	4.5	161	8.5	65	3.4	108	5.7	44	2.3
300	560	140	.25	.15	236	7.3	96	3.0	177	5.5	73	2.3	119	3.7	49	1.5
250	467	117	.24	.14	244	6.4	100	2.6	184	4.8	76	2.0	123	3.2	51	1.3
200	373	93	.23	.14	265	5.5	105	2.2	192	4.1	79	1.7	128	2.8	53	1.1
150	280	70	.22	.13	269	4.2	112	1.8	202	3.2	85	1.3	135	2.1	57	.89
125	233	58	.21	.12	279	3.7	117	1.6	209	2.7	88	1.2	140	1.8	59	.79
100	187	47	.20	.12	290	3.0	123	1.3	218	2.3	92	.98	146	1.5	62	.66
50	93	23	.18	.10	327	1.7	141	.75	245	1.3	106	.57	164	.87	71	.38

BD 200 L (i = 12) H (i = 36) TR 160 x 16 (Single start)

n rpm	v mm/min		η_d		1000 kN				800 kN				700 kN				600 kN			
	L	H	L	H	T Nm	L kW	P Nm	H kW	T Nm	L kW	P Nm	H kW	T Nm	L kW	P Nm	H kW	T Nm	L kW	P Nm	H kW
850	1133	378	.26	.18							304	27	561	50	267	24	481	43	229	20
750	1000	333	.25	.18							313	25	574	45	274	22	493	39	255	19
500	667	222	.23	.16					708	37	342	18	620	32	300	16	532	28	258	14
300	400	133	.21	.14	978	31	480	15	783	25	384	12	686	22	337	11	588	19	289	9.0
250	333	111	.20	.14	1014	27	500	13	812	22	400	10	711	19	351	9.1	610	16	301	7.8
200	267	89	.20	.13	1060	22	525	11	848	18	421	8.8	743	15	368	7.7	637	13	316	6.6
150	200	67	.18	.12	1121	18	560	8.8	897	14	448	7.0	785	13	393	6.2	674	11	337	5.3
100	133	44	.17	.11	1210	13	611	6.4	969	10	489	5.1	848	9.1	428	4.5	727	7.8	368	3.9
50	67	22	.15	.10	1368	7.2	704	3.7	1095	5.8	563	3.0	958	5.0	493	2.6	822	4.3	423	2.2

n rpm	v mm/min		η_d		500 kN				400 kN				300 kN				200 kN			
	L	H	L	H	T Nm	L kW	P Nm	H kW	T Nm	L kW	P Nm	H kW	T Nm	L kW	P Nm	H kW	T Nm	L kW	P Nm	H kW
850	1133	378	.26	.18	402	36	191	17	322	29	154	14	242	22	116	10	163	14	78	7.0
750	1000	333	.25	.18	411	32	197	16	329	26	158	13	248	19	119	9.5	166	13	80	6.4
500	667	222	.23	.16	444	23	215	11	356	19	173	9.1	268	14	130	6.9	179	9.4	88	4.6
300	400	133	.21	.14	491	16	241	7.5	393	12	194	6.1	296	9.4	146	4.6	198	6.3	98	3.1
250	333	111	.20	.14	508	14	251	6.5	407	11	202	5.2	306	8.2	152	4.0	205	5.5	102	2.7
200	267	89	.20	.13	531	11	264	5.5	426	8.8	212	4.4	320	6.6	160	3.3	214	4.5	107	2.3
150	200	67	.18	.12	562	9.0	281	4.4	450	7.2	226	3.5	338	5.4	170	2.7	227	3.6	114	1.8
100	133	44	.17	.11	607	6.5	307	3.2	486	5.2	246	2.6	365	3.9	185	1.9	245	2.6	125	1.3
50	67	22	.15	.10	685	3.6	353	1.9	549	2.9	283	1.5	412	2.2	213	1.1	276	1.5	143	.75

Power ratings BD-BDL

Power ratings for BD-BDL with double start spindle at 40% ED/10 min or max 20% ED/hour at ambient temperature +25° C.

n = input speed (rpm)
v = lifting speed (mm/min)
 η_d = running efficiency
L = low ratio
H = high ratio
T = input torque
P = input power

Mechanical and Thermal capacities:

- Mechanical capacity = all stated values non blank areas in tables.
- Mechanical capacity with stainless worm screw:
(Grey areas in tables)
- Thermal capacity:
The figures above the line in italic style can only be used at ED lower than 20%. Thermal power must be checked. See "Intermittance factor (ED) BD/BDL".

Note: Power ratings indicate running power. Additional power will be required on start. See "Selection of jacks".

BD 27 L (i = 9) H (i = 27) TR 20 x 8 (Double start)

n rpm	v mm/min		η _d		8 kN				6 kN				4 kN				2 kN			
	L	H	L	H	T Nm	L kW	P Nm	H kW	T Nm	L kW	P Nm	H kW	T Nm	L kW	P Nm	H kW	T Nm	L kW	P Nm	H kW
2900	2578	859	.41	.26			1.4	.43	2.0	.61	1.1	.34	1.4	.43	.82	.25	.83	.25	.53	.16
1750	1556	519	.40	.24	2.8	.51	1.5	.28	2.2	.39	1.2	.22	1.5	.28	.87	.16	.88	.16	.56	.10
1500	1333	444	.39	.23	2.8	.45	1.6	.25	2.2	.35	1.3	.20	1.5	.24	.92	.14	.88	.14	.58	.09
1000	889	296	.37	.22	3.0	.31	1.7	.18	2.3	.24	1.3	.14	1.6	.17	.97	.10	.93	.10	.61	.06
750	667	222	.36	.21	3.1	.25	1.8	.14	2.4	.19	1.4	.11	1.7	.13	1.0	0.8	.96	.08	.63	.05
500	444	148	.34	.19	3.3	.17	1.9	.10	2.5	.13	1.5	.08	1.8	.09	1.1	0.6	1.0	.05	.66	.05
400	356	119	.33	.18	3.4	.14	2.0	.08	2.6	.11	1.6	.06	1.8	.08	1.1	.05	1.0	.05	.68	.05
300	267	89	.31	.17	3.6	.11			2.8	.08	1.6	.05	1.9	.06	1.2	.05	1.1	.05	.71	.05
200	178	59	.30	.16	3.8	.08			2.9	.06	1.8	.05	2.0	.05	1.3	.05	1.1	.05	.76	.05
100	89	30	.27	.14					3.1	.05	2.0	.05	2.2	.05	1.4	.05	1.2	.05	.83	.05
50	44	15	.25	.12					3.4	.05	2.3	.05	2.3	.05	1.6	.05	1.3	.05	.93	.05

n rpm	v mm/min		η _d		1 kN			
	L	H	L	H	T Nm	L kW	P Nm	H kW
2900	2578	859	.41	.26	.53	.16	.39	.12
1750	1556	519	.40	.24	.56	.10	.40	.07
1500	1333	444	.39	.23	.56	.09	.41	.06
1000	889	296	.37	.22	.59	.06	.42	.05
750	667	222	.36	.21	.60	.05	.44	.05
500	444	148	.34	.19	.62	.05	.45	.05
400	356	119	.33	.18	.64	.05	.46	.05
300	267	89	.31	.17	.66	.05	.47	.05
200	178	59	.30	.16	.69	.05	.50	.05
100	89	30	.27	.14	.72	.05	.54	.05
50	44	15	.25	.12	.76	.05	.59	.05

BD 40 L (i = 7) H (i = 30) TR 30 x 12 (Double start)

n rpm	v mm/min		η _d		20 kN				15 kN				10 kN				7.5 kN			
	L	H	L	H	T Nm	L kW	P Nm	H kW	T Nm	L kW	P Nm	H kW	T Nm	L kW	P Nm	H kW	T Nm	L kW	P Nm	H kW
2600	4457	1040	.51	.34	11	2.9	3.7	1.0	8.1	2.2	2.9	.77	5.5	1.5	2.0	.55	4.2	1.1	1.6	.43
1750	3000	700	.48	.32	11	2.0	3.9	.72	8.4	1.5	3.0	.56	5.7	1.0	2.1	.39	4.4	.79	1.7	.31
1500	2571	600	.48	.31	11	1.8	4.0	.63	8.6	1.4	3.1	.49	5.9	.93	2.2	.34	4.5	.71	1.7	.27
1000	1714	400	.45	.29	12	1.3	4.3	.45	9.0	.98	3.3	.35	6.1	.67	2.3	.24	4.7	.51	1.8	.19
750	1286	300	.44	.28	12	.97	4.5	.35	9.4	.73	3.5	.27	6.4	.50	2.4	.19	4.9	.38	1.9	.15
500	857	200	.41	.26	13	.68	4.8	.25	9.9	.51	3.7	.19	6.7	.35	2.6	.13	5.1	.27	2.0	.11
400	686	160	.40	.25	14	.56	5.0	.21	10	.42	3.8	.16	6.9	.29	2.7	.11	5.3	.22	2.1	.09
300	514	120	.38	.24	14	.44	5.2	.16	11	.33	4.0	.12	7.2	.23	2.8	.09	5.5	.17	2.2	.07
200	343	80	.36	.22	15	.31	5.6	.12	11	.23	4.3	.09	7.6	.16	3.0	.06	5.8	.12	2.3	.05
100	171	40	.33	.20	16	.17	6.3	.07	12	.13	4.8	.05	8.2	.09	3.3	.05	6.3	.07	2.6	.05
50	86	20	.31	.18	17	.09	6.9	.05	13	.07	5.3	.05	8.9	.05	3.6	.05	6.7	.05	2.8	.05

n rpm	v mm/min		η _d		5 kN				2.5 kN			
	L	H	L	H	T Nm	L kW	P Nm	H kW	T Nm	L kW	P Nm	H kW
2600	4457	1040	.51	.34	2.9	.80	1.2	.32	1.6	.44	.76	.21
1750	3000	700	.48	.32	3.0	.55	1.2	.23	1.7	.31	.79	.15
1500	2571	600	.48	.31	3.1	.49	1.3	.20	1.7	.27	.80	.13
1000	1714	400	.45	.29	3.2	.35	1.3	.14	1.8	.19	.84	.09
750	1286	300	.44	.28	3.4	.26	1.4	.11	1.9	.14	.86	.07
500	857	200	.41	.26	3.5	.18	1.5	.08	1.9	.10	.90	.05
400	686	160	.40	.25	3.6	.15	1.5	.06	2.0	.08	.93	.05
300	514	120	.38	.24	3.8	.12	1.6	.05	2.1	.06	.95	.05
200	343	80	.36	.22	4.0	.08	1.7	.05	2.2	.05	1.0	.05
100	171	40	.33	.20	4.3	.05	1.8	.05	2.3	.05	1.1	.05
50	86	20	.31	.18	4.6	.05	2.0	.05	2.5	.05	1.2	.05

BD 58 L (i = 6.75) H (i = 27) TR 40 x 14 (Double start)

n rpm	v mm/min		η _d		40 kN				30 kN				25 kN				20 kN			
	L	H	L	H	T Nm	L kW	P Nm	H kW	T Nm	L kW	P Nm	H kW	T Nm	L kW	P Nm	H kW	T Nm	L kW	P Nm	H kW
2000	4148	1037	.50	.33	26	5.5	9.8	2.1	20	4.2	7.5	1.6	17	3.5	6.3	1.4	13	2.8	5.2	1.1
1750	3630	907	.49	.32	27	4.9	10	1.8	20	3.7	7.7	1.4	17	3.1	6.5	1.2	14	2.5	5.3	.95
1500	3111	778	.48	.31	27	4.2	10	1.6	20	3.2	7.9	1.2	17	2.7	6.6	1.0	14	2.1	5.4	.84
1000	2074	519	.46	.29	28	3.0	11	1.2	21	2.3	8.5	.91	18	1.9	7.1	.77	14	1.5	5.8	.63
750	1556	389	.44	.28	29	2.3	12	.92	22	1.7	8.9	.70	19	1.5	7.5	.59	15	1.2	6.1	.48
500	1037	259	.42	.26	31	1.6	13	.66	23	1.2	9.6	.50	20	1.0	8.1	.42	16	.81	6.6	.34
400	830	207	.41	.25	32	1.3	13	.55	24	.98	10	.42	20	.82	8.4	.35	16	.66	6.8	.29
300	622	156	.39	.23	33	1.0	14	.44	25	.75	11	.33	21	.63	8.9	.28	17	.51	7.2	.23
200	415	104	.37	.21	35	.74	15	.31	26	.56	11	.24	22	.47	9.6	.20	18	.38	7.8	.16
100	207	52	.34	.19	38	.40	17	.18	29	.30	13	.14	24	.25	11	.11	19	.20	8.8	.09
50	104	26	.31	.17	42	.22	19	.10	31	.17	15	.08	26	.14	12	.06	21	.11	10	.05

n rpm	v mm/min		η _d		15 kN				10 kN			
	L	H	L	H	T Nm	L kW	P Nm	H kW	T Nm	L kW	P Nm	H kW
2000	4148	1037	.50	.33	10	2.1	4.0	.86	6.9	1.5	2.8	.61
1750	3630	907	.49	.32	10	1.9	4.1	.73	7.0	1.3	2.9	.52
1500	3111	778	.48	.31	10	1.6	4.2	.65	7.1	1.1	3.0	.46
1000	2074	519	.46	.29	11	1.2	4.5	.48	7.5	.79	3.2	.34
750	1556	389	.44	.28	11	.89	4.7	.37	7.7	.61	3.3	.26
500	1037	259	.42	.26	12	.62	5.0	.26	8.1	.42	3.5	.19
400	830	207	.41	.25	12	.50	5.2	.22	8.4	.34	3.7	.15
300	622	156	.39	.23	13	.39	5.5	.18	8.7	.26	3.9	.12
200	415	104	.37	.21	13	.28	5.9	.12	9.2	.19	4.1	.09
100	207	52	.34	.19	15	.15	6.7	.07	10	.10	4.7	.05
50	104	26	.31	.17	16	.08	7.6	.05	11	.06	5.2	.05

BD 66 L (i = 7) H (i = 28) TR 55 x 18 (Double start)

n rpm	v mm/min		η _d		120 kN				100 kN				75 kN				50 kN			
	L	H	L	H	T Nm	L kW	P Nm	H kW	T Nm	L kW	P Nm	H kW	T Nm	L kW	P Nm	H kW	T Nm	L kW	P Nm	H kW
1750	4500	1125	.50	.33													41	7.5	15	2.8
1500	3857	964	.49	.33													41	6.5	16	2.4
1000	2571	643	.47	.30													43	4.6	17	1.7
750	1929	482	.45	.29									67	5.3			45	3.5	18	1.4
500	1286	321	.43	.27									71	3.7	28	1.5	48	2.5	19	1.0
300	771	193	.40	.24									76	2.4	31	.98	51	1.6	21	.66
250	643	161	.39	.23					104	2.7			78	2.0	32	.84	52	1.4	22	.57
200	514	129	.38	.22					108	2.3			81	1.7	34	.70	54	1.2	23	.47
150	386	96	.36	.21					112	1.8			84	1.4	36	.56	56	.90	24	.38
125	321	80	.35	.20					115	1.5	49	.64	86	1.1	37	.48	58	.75	25	.32
100	257	64	.34	.20	142	1.5			118	1.3	51	.53	89	.94	38	.40	59	.63	26	.27
50	129	32	.31	.17	154	.81	69	.36	129	.68	58	.30	97	.51	43	.23	65	.34	29	.15

n rpm	v mm/min		η _d		25 kN				20 kN				10 kN			
	L	H	L	H	T Nm	L kW	P Nm	H kW	T Nm	L kW	P Nm	H kW	T Nm	L kW	P Nm	H kW
1750	4500	1125	.50	.33	21	3.8	7.9	1.5	17	3.1	6.4	1.2	8.6	1.6	3.5	.65
1500	3857	964	.49	.33	21	3.3	8.1	1.2	17	2.7	6.6	1.0	8.8	1.4	3.6	.56
1000	2571	643	.47	.30	22	2.3	8.6	.88	18	1.9	7.0	.72	9.2	.97	3.8	.39
750	1929	482	.45	.29	23	1.8	9.1	.72	18	1.4	7.4	.59	9.5	.75	4.0	.32
500	1286	321	.43	.27	24	1.3	9.8	.52	19	1.0	7.9	.42	10	.52	4.3	.23
300	771	193	.40	.24	26	.81	11	.34	21	.65	8.7	.28	11	.34	4.7	.15
250	643	161	.39	.23	27	.69	11	.29	21	.55	9.0	.24	11	.28	4.8	.13
200	514	129	.38	.22	27	.58	12	.24	22	.47	9.4	.20	11	.24	5.0	.10
150	386	96	.36	.21	28	.46	12	.19	23	.37	9.9	.16	12	.19	5.3	.08
125	321	80	.35	.20	29	.38	13	.17	23	.31	10	.13	12	.16	5.4	.07
100	257	64	.34	.20	30	.32	13	.14	24	.26	11	.11	12	.13	5.7	.06
50	129	32	.31	.17	33	.17	15	.08	26	.14	12	.06	13	.07	6.3	.05

BD 86 L (i = 7) H (i = 28) TR 65 x 20 (Double start)

n rpm	v mm/min		η _d		160 kN				120 kN				100 kN				75 kN						
	L	H	L	H	T	L	P	T	H	P	T	L	P	T	H	P	T	L	P	T	H	P	
					Nm	kW	Nm	kW	Nm	kW	Nm	kW	Nm	kW	Nm	kW	Nm	kW	Nm	kW	Nm	kW	Nm
1500	4286	1071	.49	.34												91	14	33	5.2	69	11	25	3.9
1000	2857	714	.47	.32							114	12	42	4.4	96	10	35	3.7	72	7.5	27	2.8	
750	2143	536	.45	.30							119	9.3	44	3.5	99	7.8	37	2.9	75	5.8	28	2.2	
500	1429	357	.43	.28							125	6.6	48	2.5	105	5.5	40	2.1	79	4.1	30	1.6	
300	857	214	.40	.26	179	5.6	70	2.2			135	4.2	53	1.7	112	3.5	44	1.4	84	2.6	33	1.0	
250	714	179	.39	.25	184	4.8	72	1.9			138	3.6	54	1.4	115	3.0	46	1.2	87	2.3	34	.90	
200	571	143	.38	.24	190	4.0	75	1.6			142	3.0	57	1.2	119	2.5	48	1.0	89	1.9	36	.76	
150	429	107	.36	.22	197	3.1	80	1.3			148	2.3	60	.98	124	1.9	50	.82	93	1.5	38	.62	
125	357	89	.35	.22	202	2.7	82	1.1			152	2.0	62	.83	127	1.7	52	.69	95	1.3	39	.52	
100	286	71	.34	.21	209	2.2	86	.90			157	1.7	65	.68	131	1.4	54	.57	98	1.0	41	.43	
50	143	36	.31	.18	228	1.2	97	.51			171	.90	73	.38	143	.75	61	.32	107	.56	46	.24	

n rpm	v mm/min		η _d		50 kN				25 kN							
	L	H	L	H	T	L	P	T	H	P	T	L	P	T	H	P
					Nm	kW	Nm	kW	Nm	kW	Nm	kW	Nm	kW	Nm	kW
1500	4286	1071	.49	.34	46	7.1	17	2.7	23	3.6	8.8	1.4				
1000	2857	714	.47	.32	48	5.1	18	1.9	25	2.6	9.4	.99				
750	2143	536	.45	.30	50	3.9	19	1.5	25	2.0	9.9	.78				
500	1429	357	.43	.28	53	2.8	20	1.1	27	1.4	11	.56				
300	857	214	.40	.26	57	1.8	22	.71	29	.90	12	.37				
250	714	179	.39	.25	58	1.5	23	.61	29	.77	12	.32				
200	571	143	.38	.24	60	1.3	24	.51	30	.64	13	.27				
150	429	107	.36	.22	62	.98	25	.42	32	.50	13	.21				
125	357	89	.35	.22	64	.85	26	.35	32	.43	14	.18				
100	286	71	.34	.21	66	.69	27	.29	33	.35	14	.15				
50	143	36	.31	.18	72	.38	31	.16	36	.19	16	.08				

BD 100 L (i = 7) H (i = 28) TR 90 x 24 (Double start)

n rpm	v mm/min		η _d		240 kN				200 kN				150 kN				100 kN						
	L	H	L	H	T	L	P	T	H	P	T	L	P	T	H	P	T	L	P	T	H	P	
					Nm	kW	Nm	kW	Nm	kW	Nm	kW	Nm	kW	Nm	kW	Nm	kW	Nm	kW	Nm	kW	Nm
1000	3429	857	.46	.31															118	12	43	4.6	
750	2571	643	.44	.30												183	14	68	5.4	122	9.4	46	3.6
500	1714	429	.42	.27												193	10	74	3.9	129	6.7	49	2.6
300	1029	257	.39	.25							277	8.7				208	6.5	82	2.6	139	4.4	55	1.7
250	857	214	.38	.24							285	7.5				214	5.6	85	2.2	143	3.8	57	1.5
200	686	171	.37	.23							294	6.2	118	2.5		221	4.7	89	1.9	148	3.1	59	1.3
150	514	129	.35	.21	369	5.8					307	4.8	125	2.0		231	3.6	94	1.5	154	2.4	63	1.0
125	429	107	.34	.21	379	5.0					316	4.2	129	1.7		237	3.1	97	1.3	158	2.1	65	.86
100	343	86	.33	.20	391	4.1					326	3.4	135	1.4		245	2.6	102	1.1	164	1.7	68	.71
50	171	43	.30	.17	431	2.3	184	.96			359	1.9	154	.80		270	1.4	115	.60	180	.96	77	.40

n rpm	v mm/min		η _d		75 kN				50 kN							
	L	H	L	H	T	L	P	T	H	P	T	L	P	T	H	P
					Nm	kW	Nm	kW	Nm	kW	Nm	kW	Nm	kW	Nm	kW
1000	3429	857	.46	.31	89	9.0	33	3.5			59	6.1	22	2.4		
750	2571	643	.44	.30	92	7.0	35	2.7			62	4.7	23	1.9		
500	1714	429	.42	.27	97	5.0	37	2.0			65	3.4	25	1.3		
300	1029	257	.39	.25	105	3.3	41	1.3			70	2.2	28	0.9		
250	857	214	.38	.24	107	2.8	43	1.1			72	1.9	29	.75		
200	686	171	.37	.23	111	2.3	45	.95			74	1.6	30	.64		
150	514	129	.35	.21	116	1.8	47	.76			78	1.2	32	.51		
125	429	107	.34	.21	119	1.6	49	.65			80	1.1	33	.44		
100	343	86	.33	.20	123	1.3	51	.53			82	.86	35	.36		
50	171	43	.30	.17	135	.72	58	.30			91	.48	39	.20		

Intermittance factor (ED) BD/BDL

Intermittance factor, if the ED is other than 20%/hour the running power (P_D) must be adjusted according to diagram which is calculated by following formula:

$$P_{ED} = \frac{20\%}{ED\%} \times P_{max}$$

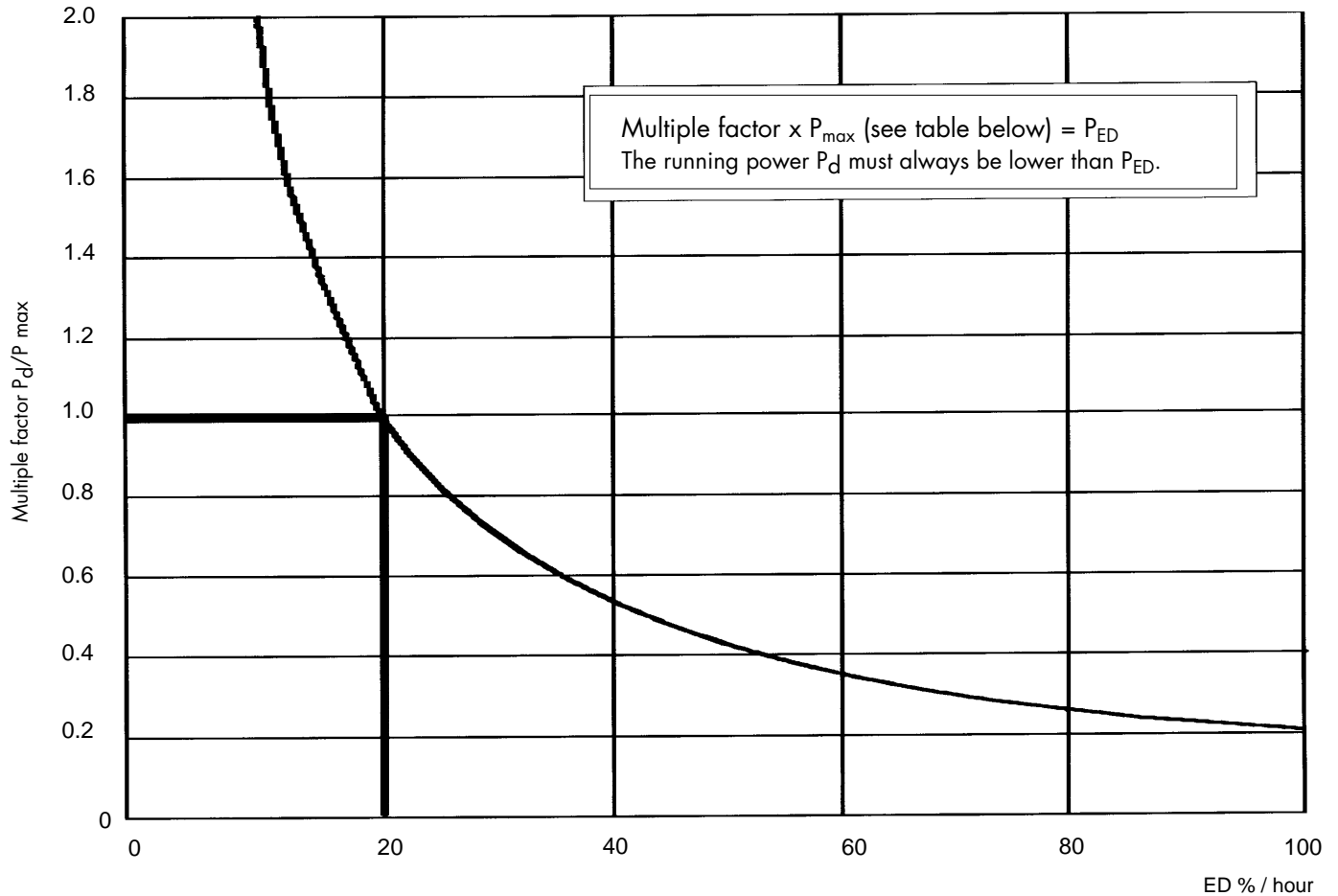

Thermal rating at 20% ED (1-start spindle)

Size BD-BDL		27	40	58	66	86	100	125	200
P_{max} kW	L	0.2	.55	0.9	1.5	2.9	3.7	5.1	12.5
	H	0.15	.5	0.8	1.3	2.6	3.3	4.5	12.0

Thermal rating at 20% ED (2-start spindle)

Size BD-BDL		27	40	58	66	86	100	125	200
P_{max} kW	L	0.25	0.7	1.1	1.9	3.6	4.7	6.4	16.0
	H	0.20	0.6	1.0	1.6	3.2	4.1	5.6	15.0

Critical travelling nut speed

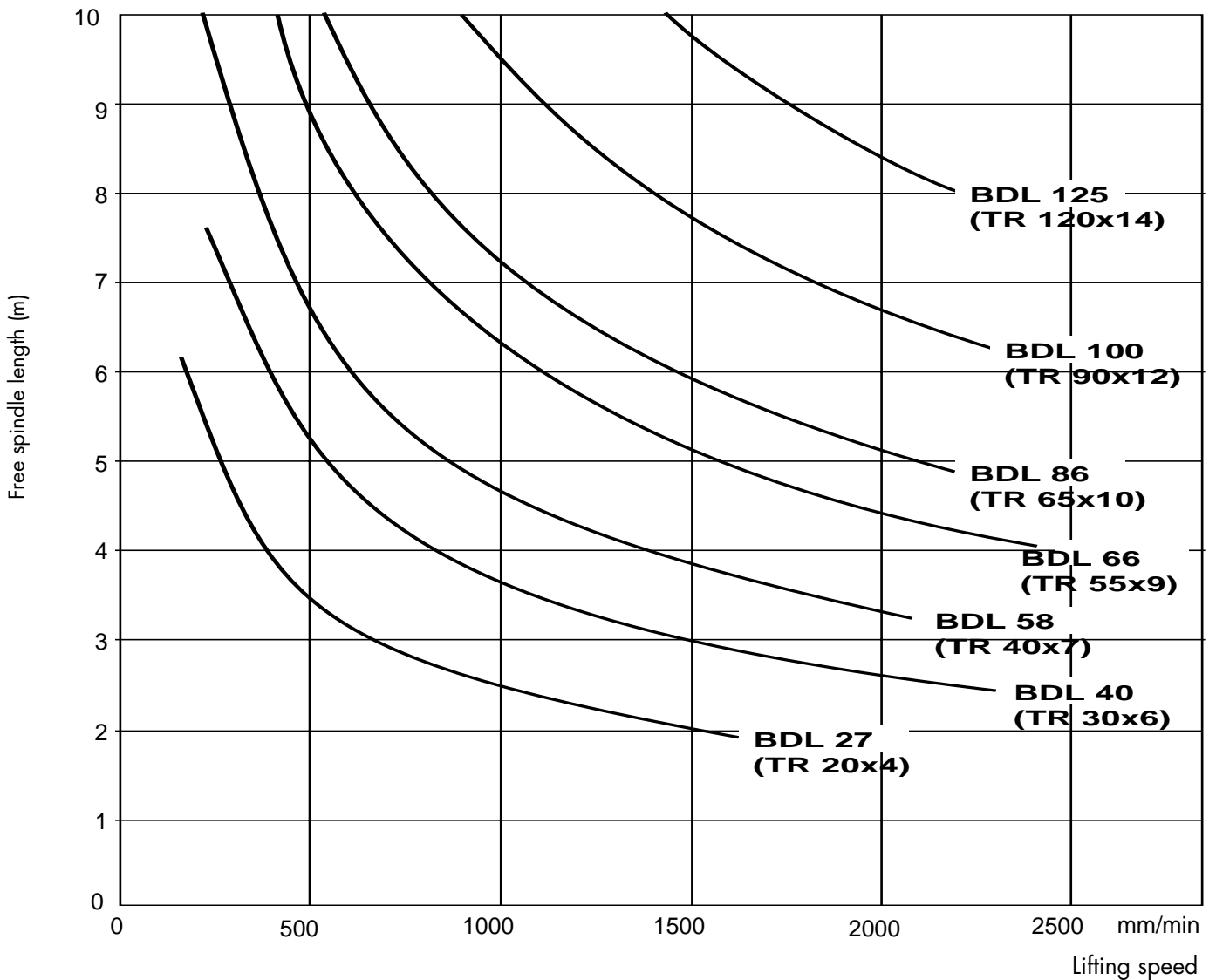

Max permissible speed V mm/min with grease lubrication

BD-BDL Single start	Ratio		BD/BDL Double start	Ratio L
	L	H		
27	1600	500	27	3200
40	2300	500	40	4600
58	2100	500	58	4200
66	2400	600	66	4800
86	2200	550	86	4400
100	2300	550	100	4600
125	2200	550	125	4400
200	1180	410	200	2360

Allowable side force on the spindle BD

F_a = thrust load on spindle (kN)
 F_r = side force on the spindle (kN)
 l = length of stroke (mm)

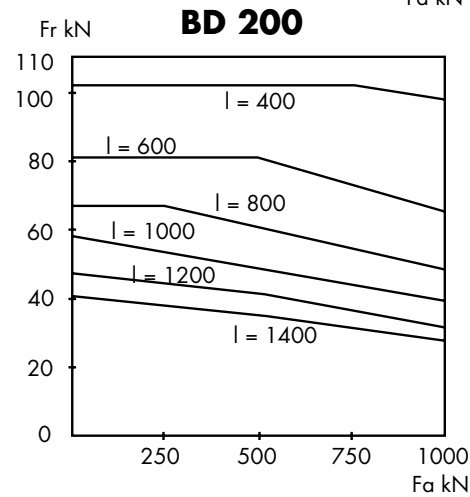
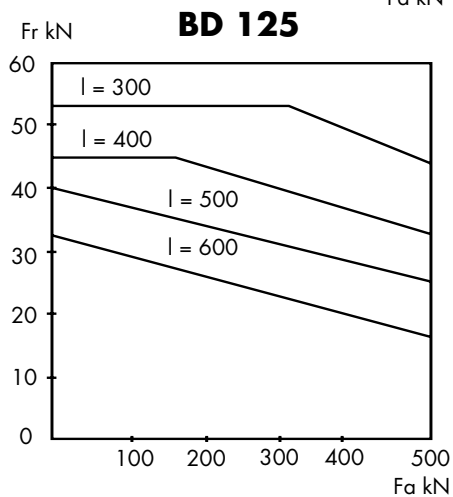
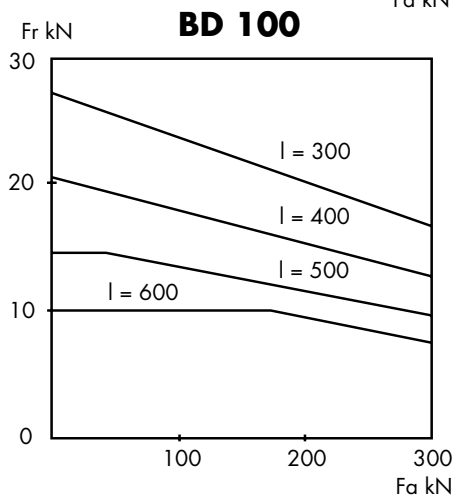
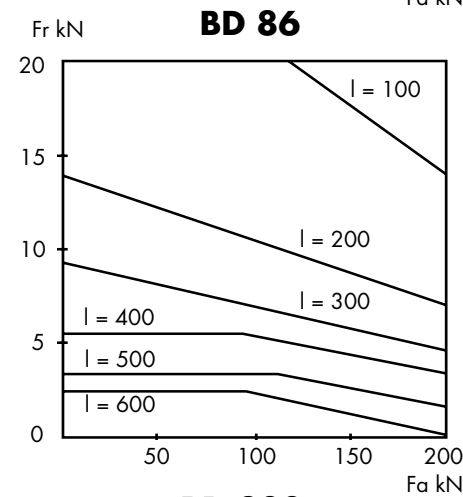
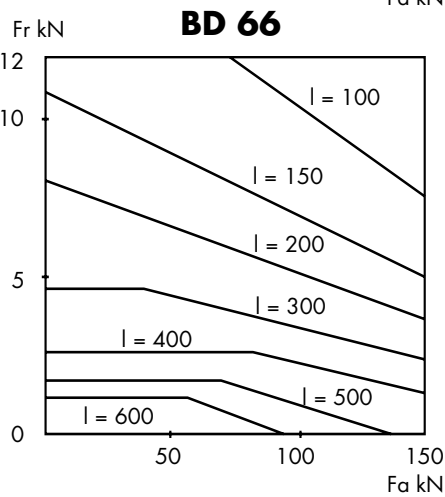
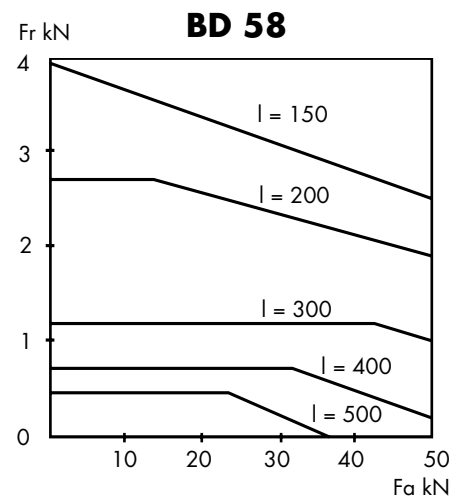
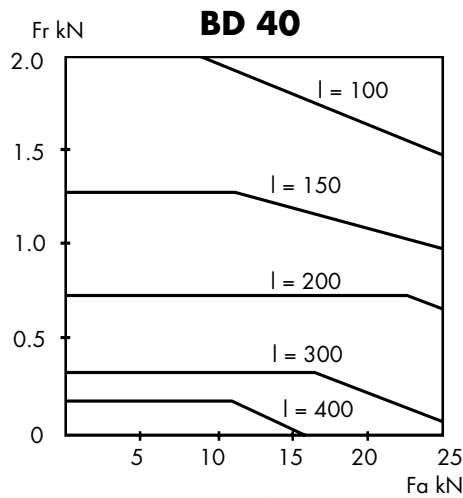
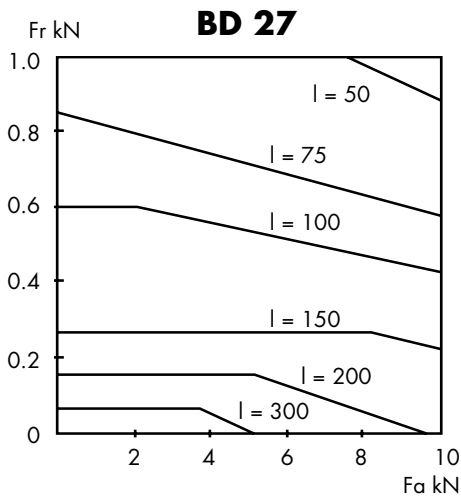
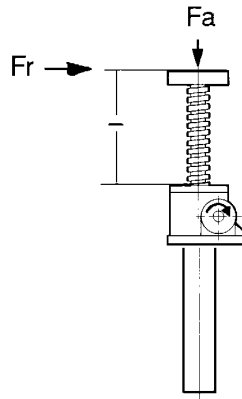

Dimensions

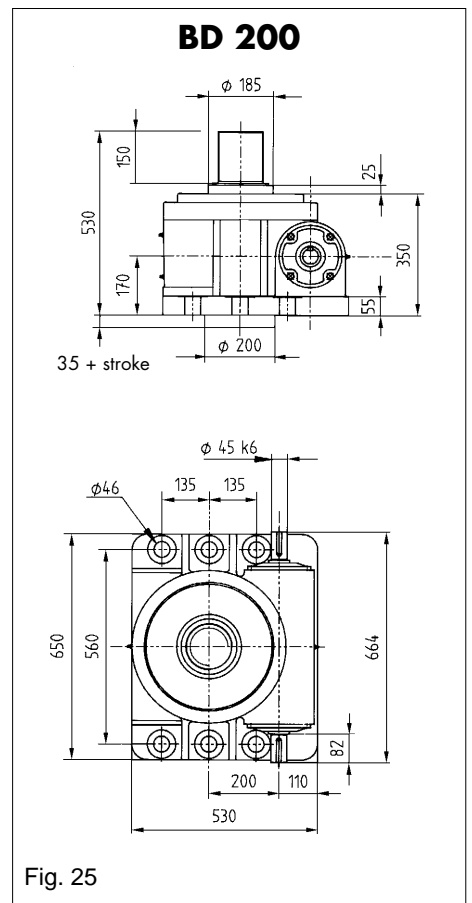
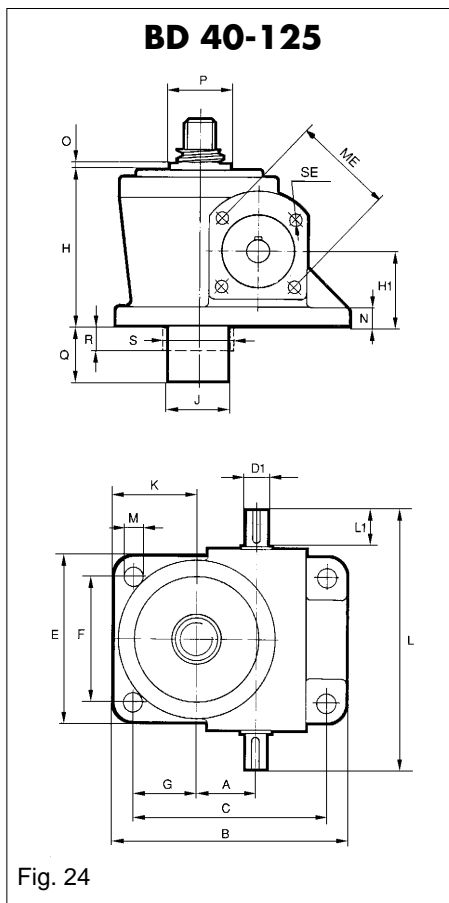
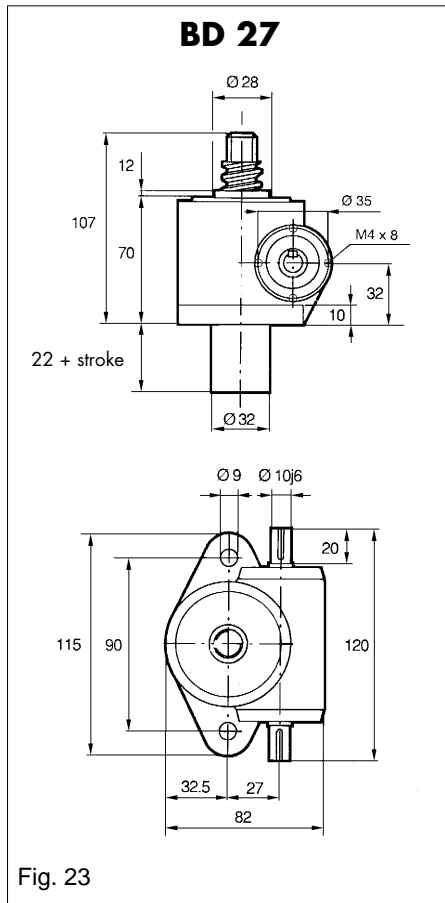

Size	40	58	66	86	100	125
A	40	58	66	86	100	125
B	156	196	222	300	350	460
C	130	158	178	250	280	380
Ø D1j6	14	19	24	30	35	38
E	110	170	190	220	260	300
F	84	134	146	170	190	220
G	42	40	51	85	95	140
H	105	130	157	182	225	275
H1	50	55	68	80	102	125
Ø J	45	55	75	90	120	150
K	55	60	73	110	130	180
L	172	237	268	318	356	486
L1	25	35	40	47	58	58
Ø M	13	18	21	26	35	42
N	12	12	16	20	25	35
O	15	15	15	20	20	25
Ø P	40	50	70	80	110	140
Q	25 + Stroke	25 + Stroke	25 + Stroke	45 + Stroke	45 + Stroke	55 + Stroke
R	-	-	-	45	45	55
S	-	-	-	100	132	160
SE	M8 x 12	M8 x 12	M8 x 12	M10 x 15	M10 x 15	-
ME	65	80	80	88	96	-

Keyway BS 4235

Dimensions BD 27-200 End execution 1, 2, 3

Execution 1

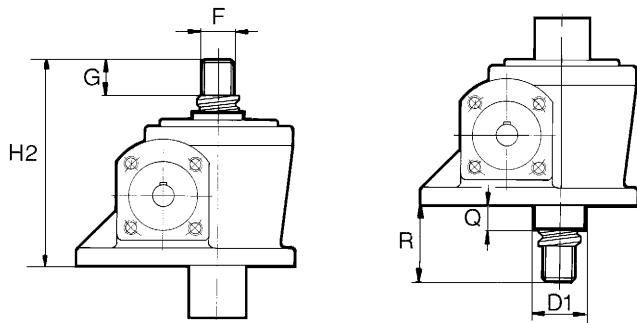

Fig. 26

Execution 3

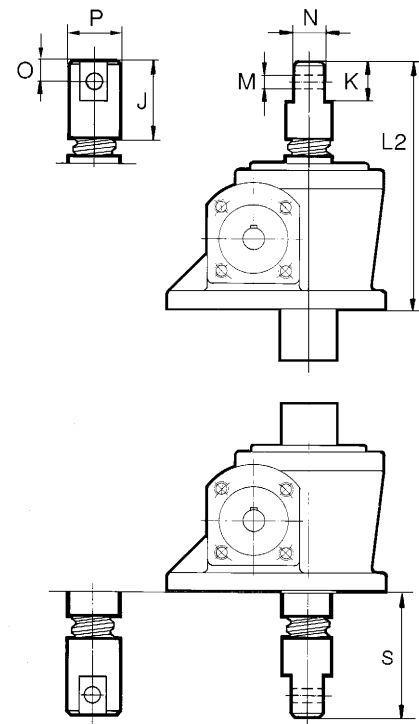

Fig. 28

Execution 2

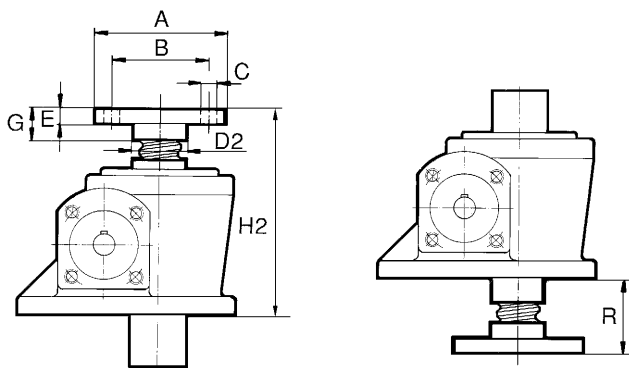

Fig. 27

Size	27	40	58	66	86	100	125	200
Ø A	65	92	122	150	185	215	285	380
Ø B	50	65	90	110	140	170	220	290
Ø C	4x7	4x14	4x18	4x21	4x26	6x26	6x33	6x48
Ø D1	28	40	50	70	80	110	140	185
Ø D2	30	40	55	70	90	120	150	200
E	8	12	16	20	25	25	32	60
F	M14x2	M20x1.5	M30x2	M40x3	M50x3	M70x4	M90x4	M130x4
G	20	25	36	50	60	85	110	150
H2	107	150	186	227	267	335	415	530
J	55	75	100	125	160	200	265	360
K	25	35	50	60	80	100	130	180
L2	142	200	250	302	367	450	570	740
Ø M H11	12	18	25	30	40	50	65	90
N	20	25	35	45	60	80	100	140
O	12.5	17.5	25	30	40	50	65	90
Ø P	30	40	55	70	90	120	150	200
Q	12	15	15	15	20	20	25	25
R	37	45	56	70	85	110	140	180
S	72	95	120	145	185	225	295	390

Dimensions BDL 27-200

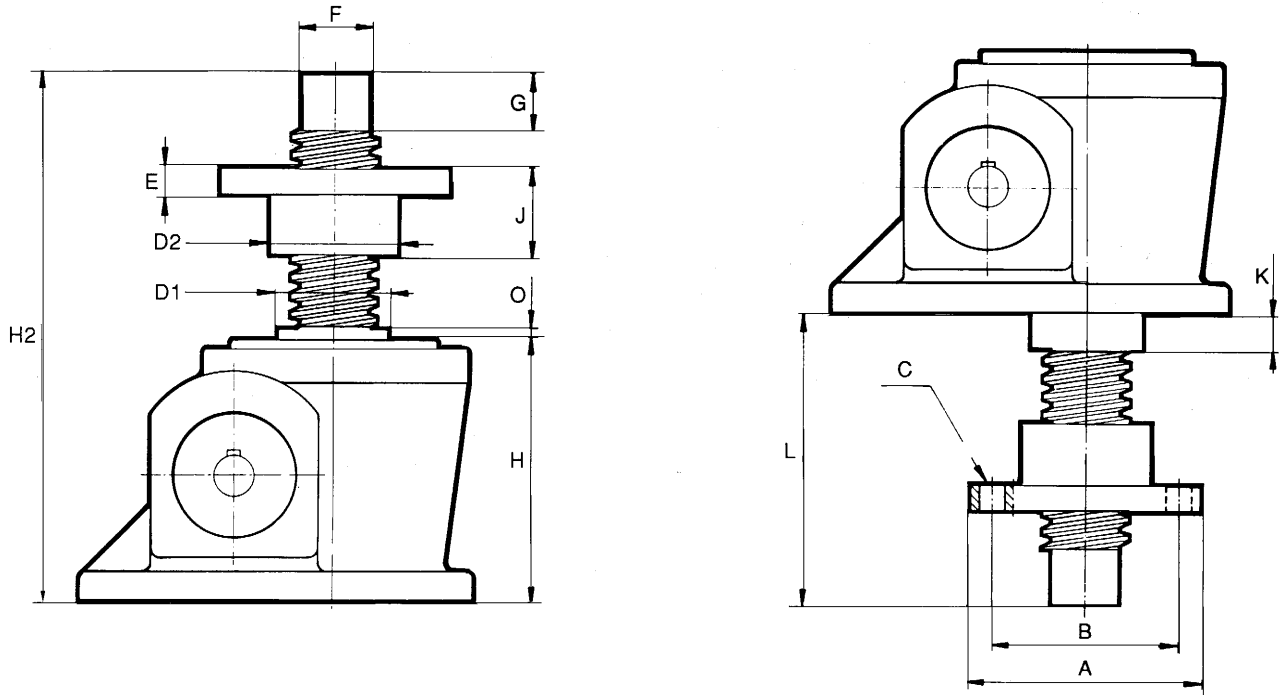

Fig. 29

Size	27	40	58	66	86	100	125	200
Ø A	65	92	122	150	185	215	285	380
Ø B	50	65	90	110	140	170	220	290
Ø C	4x7	4x14	4x18	4x21	4x26	6x26	6x33	6x48
Ø D1	28	40	50	70	80	110	140	185
Ø D2	30	40	55	70	90	120	150	200
E	10	15	20	25	30	35	50	90
Ø F h7	12	20	30	40	50	70	100	140
G	20	30	40	60	60	90	120	160
H	70	105	130	157	182	225	275	350
H2	148 + Stroke	215 + Stroke	265 + Stroke	332 + Stroke	365 + Stroke	465 + Stroke	580 + Stroke	770 + Stroke
J	25	40	55	75	85	110	140	200
K	12	15	15	15	20	20	25	25
L	84 + Stroke	115 + Stroke	155 + Stroke	196 + Stroke	205 + Stroke	261 + Stroke	330 + Stroke	430 + Stroke
O	12	15	15	15	8	10	10	25

Dimensions with PVC bellows BD 27-125

BD 200 contact Benzlers

BD 27-125

BDL 27-125

Fig. 30

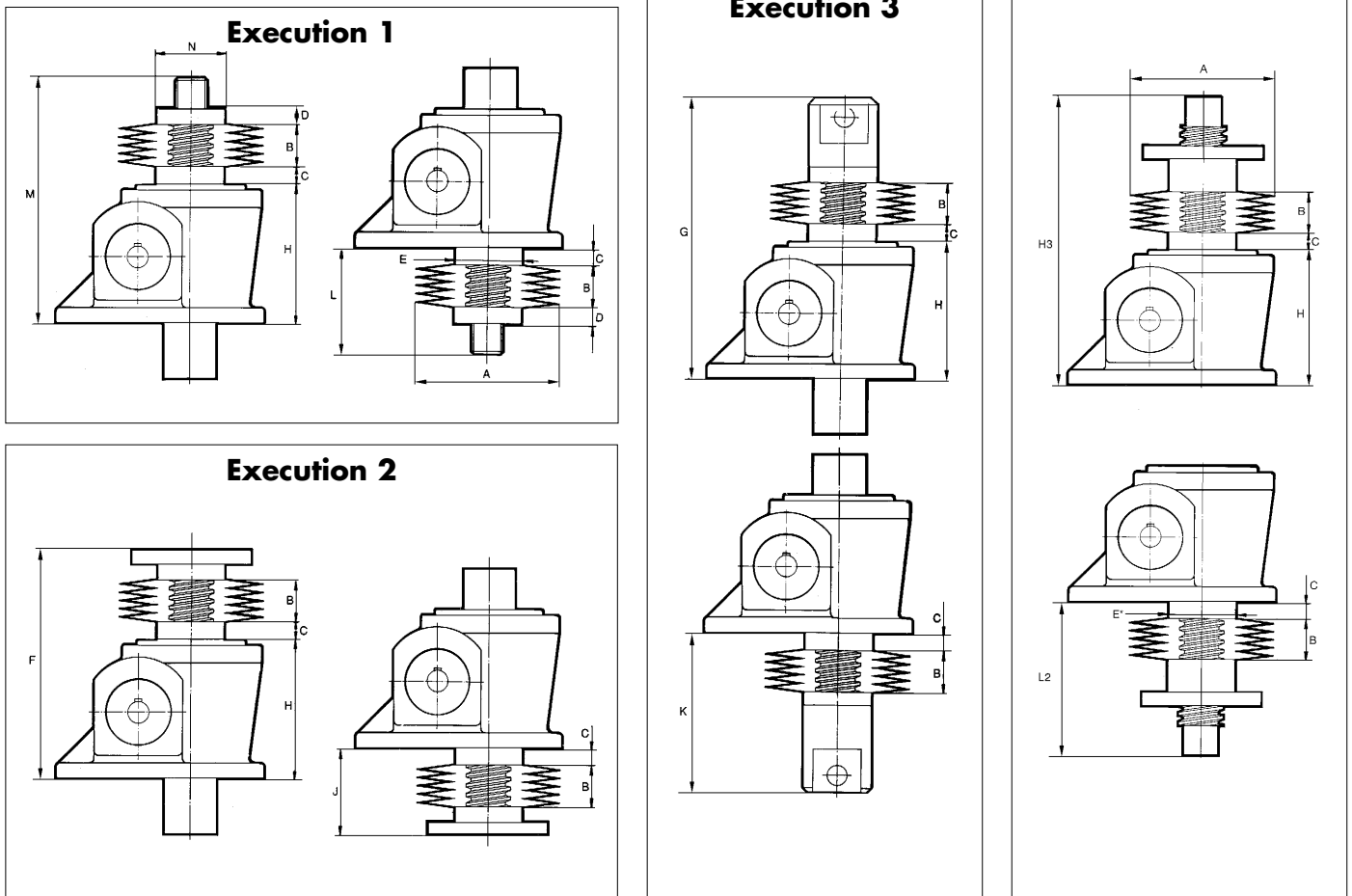

Size	27	40	58	66	86	100	125
Ø A	95	115	130	150	190	225	270
B	min 5	5	5	5	5	5	5
	max 0.05 x Stroke	0.05 x Stroke	0.05 x Stroke	0.05 x Stroke	0.05 x Stroke	0.05 x Stroke	0.05 x Stroke
C	12	15	15	15	20	20	25
D	15	15	15	15	15	15	15
Ø E*	28	40	50	70	80	110	140
F	102 + B	145 + B	181 + B	222 + B	262 + B	330 + B	410 + B
G	137 + B	195 + B	245 + B	297 + B	362 + B	445 + B	565 + B
H	70	105	130	157	182	225	275
H3	148 + 1.05 x stroke	215 + 1.05 x stroke	265 + 1.05 x stroke	332 + 1.05 x stroke	365 + 1.05 x stroke	465 + 1.05 x stroke	580 + 1.05 x stroke
J	32 + B	40 + B	51 + B	65 + B	80 + B	105 + B	135 + B
K	67 + B	90 + B	115 + B	140 + B	180 + B	220 + B	290 + B
L	47 + B	55 + B	66 + B	80 + B	95 + B	120 + B	150 + B
L2	L + 0.05 x Stroke						
M	117 + B	160 + B	196 + B	237 + B	277 + B	345 + B	425 + B
N	30	40	55	70	90	120	150

*Hole for hose clamp ØE + 30

Options

STOP NUT (SM)

Stop nuts can be fitted to all Benzler screw jacks, both above and below the main body.

These must be included when there is an inherent risk of over travel resulting in the spindle becoming disengaged from the worm thread.

- 1 Stop nut
- 2 Protection tube
- 3 Tube sleeve

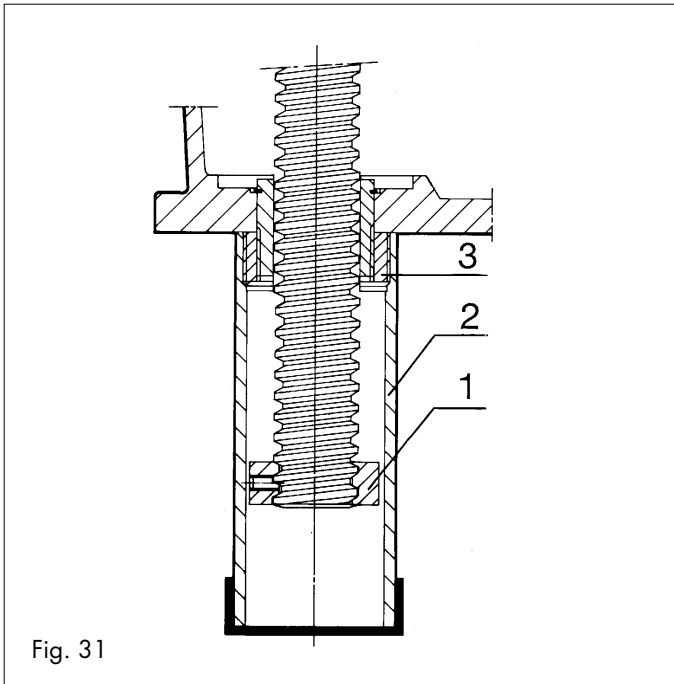

STOP NUT (SM) + LIMIT SWITCH (LS)

Benzler jacks can be supplied with limit switches to suit most applications. Standard is two limit switches and one stop nut.

Upper/lower limits can be mounted on the protection tube. Adjustable limits are also available on request.

- 1 Stop nut
- 2 Carrier
- 3 Limit switch

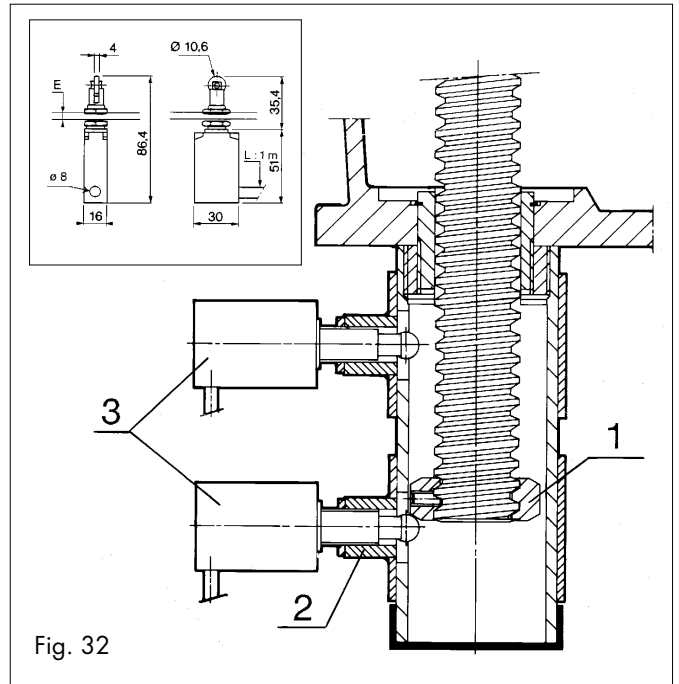

SAFETY NUT (SHM)

In certain applications the addition of a safety nut may be required. The object of the above is to prevent the load collapsing in the event of the lifting nut thread failing.

Monitoring of the safety gap between the lifting and safety nut gives an indication of the intermediate wear. When the safety gap reaches zero the lifting nut has reached its wear limit and requires changing. In applications where the safety nut is inaccessible, electro/mechanical switches are available to indicate maximum wear.

- 1 Safety nut
- 2 Spacer
- 3 Worm wheel

Load direction important!

Combinations with other options are restricted. Consult Benzlers for more information.

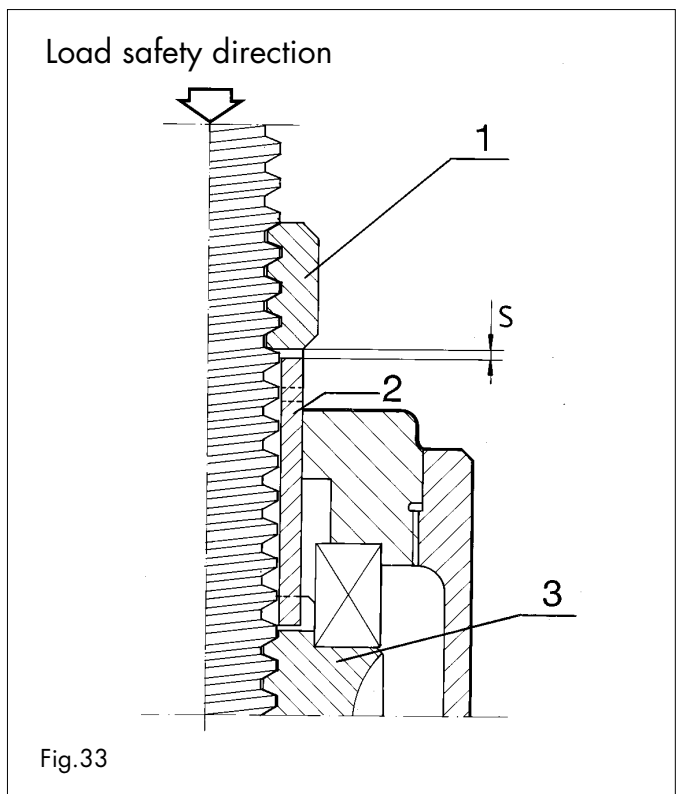

LOCKED AGAINST ROTATION

For applications where a load is to be raised/lowered and permanent fixing i.e. top plate/clevis, is not practical, the spindle must be prevented from rotating.

Two options are available:

I) LR - Locked Against Rotation (Tube)

Protection tube manufactured in box section mild steel.

Spindle end complete with nut (sized to suit box section).

- 1 Gear housing
- 2 Locking nut
- 3 Locking assembly (size dependent variant 1)
- 4 Tube
- 5 Pin (size dependent variant 2)

II) LRK - Locked Against Rotation (Key)

Jack internals are modified to incorporate a rectangular key which engages in a precision keyway cut into the spindle length. Primarily used in precision applications requiring minimal radial movement.

- 1 Jack cover
- 2 Lifting screw
- 3 Key

Combinations with other options are restricted.

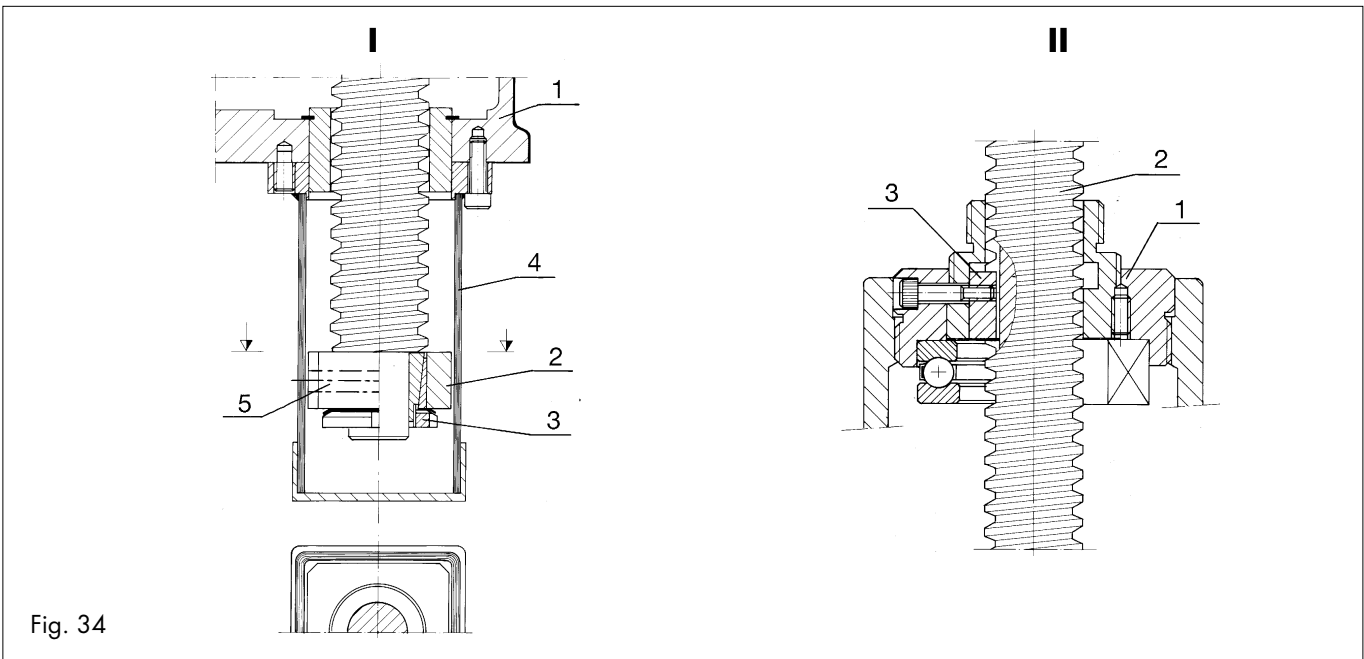

ANTIBACKLASH (ABL)

Where the loading on a Benzler screw jack can be in both tension and compression and the spindle backlash is critical, units can be supplied with a Back-lash Eliminator comprising of a modified worm wheel fitted with a secondary nut, allowing contact on both face and flank of driving thread.

Backlash 0.01-0.05 mm - During operation excessive backlash can be removed by adjustment of the top cover. The nuts are separated by a pre-determined gap to eliminate the adjustment of the backlash eliminator when drive thread width has been reduced by 25%.

- 1 Worm wheel
- 2 Dowel pin
- 3 Adjusting nut
- 4 Jack cover

Combinations with other options are restricted.

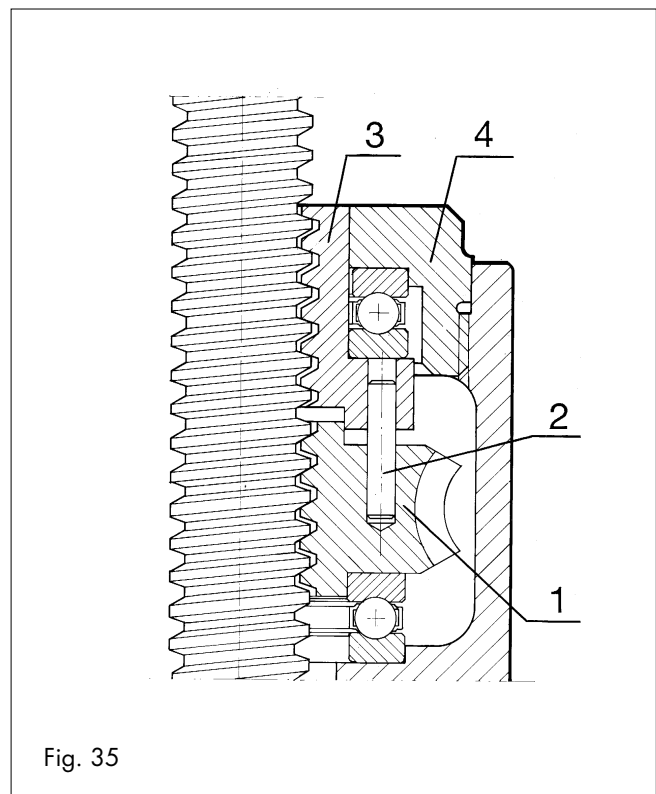

Dimensions SHM - SM - LR - LRK - ABL

Dimensions for BD86 - BD200 consult Benzlers.

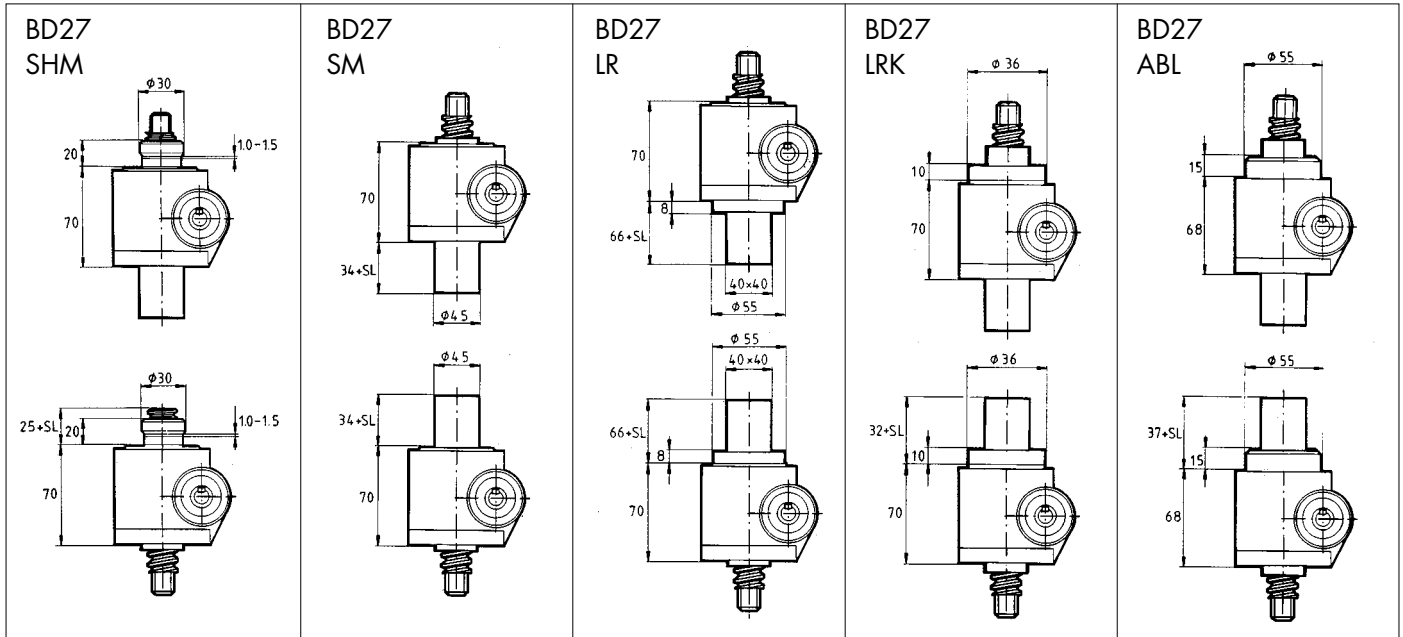

*SL = Stroke

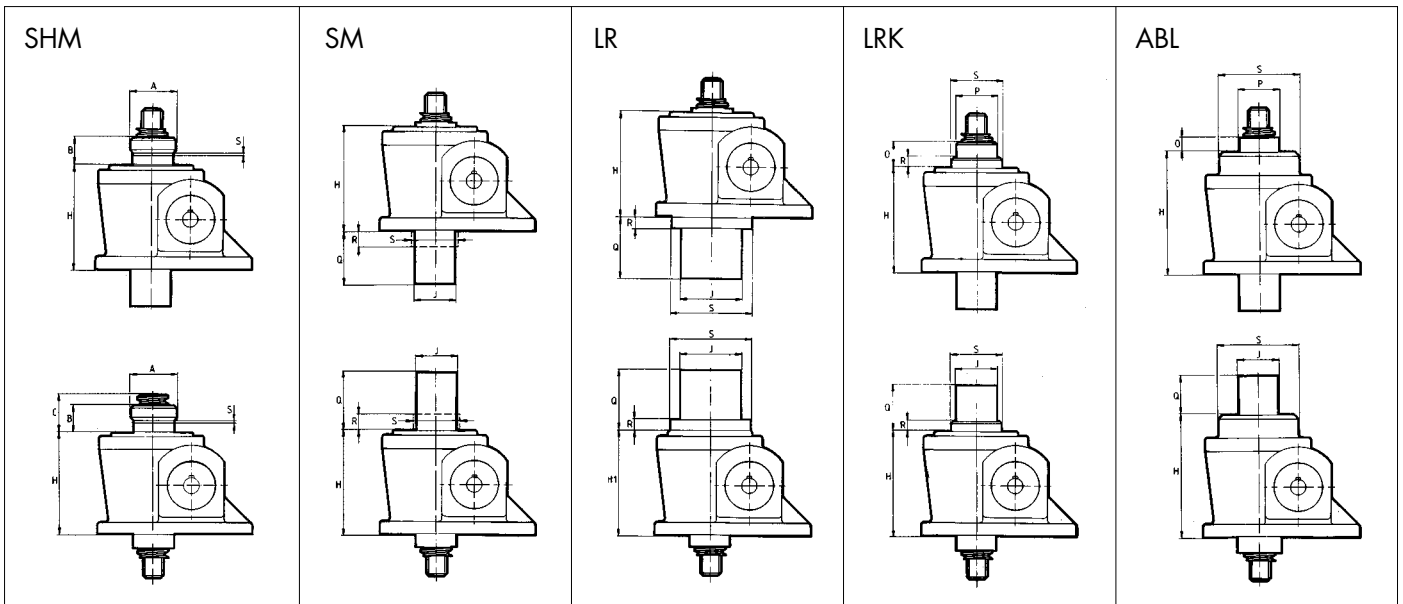

SHM

SM

LR

LRK

ABL

BD	40	58	66	40	58	66	40	58	66	40	58	66	40	58	66
Ø A	45	55	75	-	-	-	-	-	-	-	-	-	-	-	-
B	27	35	52	-	-	-	-	-	-	-	-	-	-	-	-
C	32+SL	40+SL	57+SL	-	-	-	-	-	-	-	-	-	-	-	-
H	105	130	157	105	130	157	105	130	157	105	130	157	120	152	190
H 1	-	-	-	-	-	-	103	128	155	-	-	-	-	-	-
Ø J	-	-	-	55	75	90	-	-	-	45	55	75	45	55	75
# J	-	-	-	-	-	-	60X60	70X70	80X80	-	-	-	-	-	-
O	-	-	-	-	-	-	-	-	-	20	15	30	15	15	15
Ø P	-	-	-	-	-	-	-	-	-	40	50	70	40	50	70
Q	-	-	-	43+SL	48+SL	62+SL	77+SL	86+SL	120+SL	30+SL	25+SL	40+SL	25+SL	25+SL	25+SL
R	-	-	-	-	-	37	10	10	15	5	-	15	-	-	-
S	1,5-2,2	1,8-2,5	2,3-3,3	-	-	Ø 100	Ø 80	Ø 100	Ø 110	Ø 50	-	Ø 80	Ø 80	Ø 110	Ø 120

Dimensions SHM - SM - LR - LRK - ABL

Dimensions for BD86 - BD200 consult Benzlers.

Without bellow

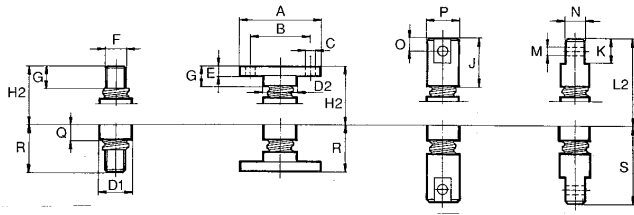

With bellow

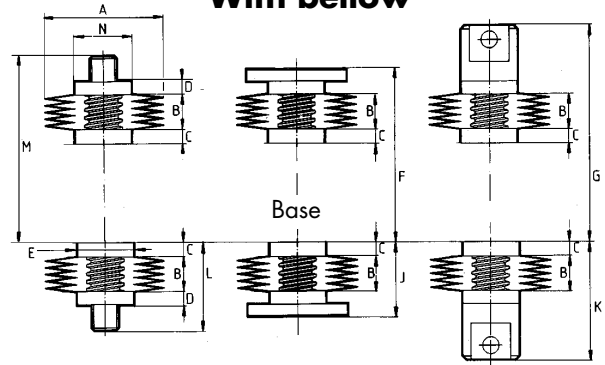

Size	27	40	58	66
Ø A	65	92	122	150
Ø B	50	65	90	110
Ø C	4 x 7	4 x 14	4 x 18	4 x 21
Ø D1	28	40	50	70
Ø D2	30	40	55	70
E	8	12	16	20
F	M14 x 2	M20 x 1,5	M30 x 2	M40 x 3
G	20	25	36	50
SHM	120	167	210	269
SM	107	150	186	227
LR H2	107	150	186	227
LRK	117	155	186	242
ABL	119	165	207	260
J	55	75	100	125
K	25	35	50	60
SHM	155	217	274	344
SM	142	200	250	302
LR L2	142	200	250	302
LRK	152	205	250	317
ABL	154	215	271	335
Ø M H11	12	18	25	30
N	20	25	35	45
O	12,5	17,5	25	30
Ø P	30	40	55	70
Q	12	15	15	15
SHM*	37/50	45/62	56/80	70/112
SM	37	45	56	70
LR R	37	45	56	70
LRK	37	45	56	70
ABL	37	45	56	70
SHM*	72/85	95/112	120/144	145/187
SM	72	95	120	145
LR S	72	95	120	145
LRK	72	95	120	145
ABL	72	95	120	145

* Alternative depending on placement of SHM.

Size	27	40	58	66
Ø A	115	115	130	150
B min max	5 0,05 x SL*	5 0,05 x SL*	5 0,05 x SL*	5 0,05 x SL*
C	12	15	15	15
D	15	15	15	15
Ø E**	28	40	50	70
SHM- SM LR LRK ABL	F 102 + B 102 + B 112 + B 114 + B	145 + B 145 + B 150 + B 165 + B	181 + B 181 + B 181 + B 203 + B	222 + B 222 + B 237 + B 288 + B
SHM- SM LR LRK ABL	G 137 + B 137 + B 147 + B 149 + B	195 + B 195 + B 200 + B 215 + B	245 + B 245 + B 245 + B 267 + B	297 + B 297 + B 312 + B 363 + B
SHM SM LR LRK ABL	J 32 + B 32 + B 32 + B 32 + B	40 + B 40 + B 40 + B 40 + B	51 + B 51 + B 51 + B 51 + B	65 + B 65 + B 65 + B 65 + B
SHM SM LR LRK ABL	K 67 + B 67 + B 67 + B 67 + B	90 + B 90 + B 90 + B 90 + B	115 + B 115 + B 115 + B 115 + B	140 + B 140 + B 140 + B 140 + B
SHM SM LR LRK ABL	L 47 + B 47 + B 47 + B 47 + B	55 + B 55 + B 55 + B 55 + B	66 + B 66 + B 66 + B 66 + B	80 + B 80 + B 80 + B 80 + B
SHM- SM LR LRK ABL	M 117 + B 117 + B 127 + B 129 + B	160 + B 160 + B 165 + B 180 + B	196 + B 196 + B 196 + B 218 + B	237 + B 237 + B 252 + B 303 + B
N	30	40	55	70

*SL = Stroke

**Hole for hose clamp ØE + 30

Description of BDK - BDKL

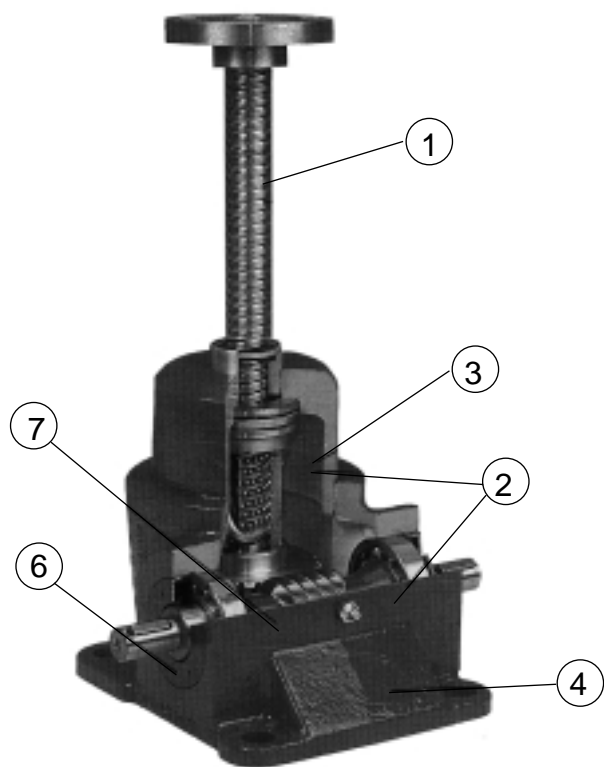

- 1 Ball screw
- 2 Thrust and radial bearings
- 3 Grease of EP-quality
- 4 Housing of nodular cast iron
- 5 Alkyd paint 85 micron thick in RAL 5015
- 6 Worm screw hardened and ground
- 7 Worm wheel of centrifugally cast tin bronze
- 8 Bellows in PVC, steel or other materials.

Benzlers ball screw jacks BDK and BDKL are at full load designed for 60% utilization (ED) per 10 minutes still not more than 30% per hour totally at ambient temperature +25°C. Benzler ball screw jacks are filled with grease in EP-quality at delivery. The lifting screw should be lubricated with same type of grease. Allowable working temperature range is from -30°C to +100° C.

**For other conditions consult Benzlers.
Other sizes on request.**

Technical data of BDK - BDKL

Other capacities and screw sizes available on request

Size	27	40	58	66
Max capacity (N)	8 000	25 000	50 000	125 000
Lifting screw	20 x 5	25 x 10	40 x 10	50 x 10
Ratio (L)	9:1	7:1	6.75:1	7:1
Raise per revolution (mm)	0.555	1.428	1.481	1.428
Starting torque at max load (Nm)	2.5	16.0	32	76
Max running power at 30% ED (kW)	0.25	0.77	2.0	2.9
Starting efficiency	0.28	0.35	0.39	0.37
Starting torque on lifting screw at max load (Nm)	9	56	114	292
Running efficiency	See page "Power ratings"			
*Holding torque (Nm))	0.35	2.5	6.0	14.0
Weight with 100 mm stroke BDK/BDKL (kg)	4/3.5	11/10	26/20	40/34
Weight of lifting screw, 100 mm (Kg)	0.2	0.32	0.84	1.36

*) The holding torque is the torque on the input shaft which is required to prevent the load from being lowered.

Compression load table BDK-BDKL Euler I

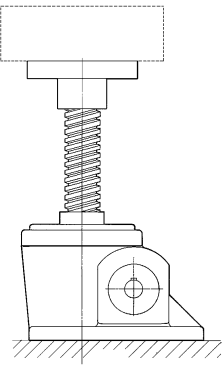
Size		27	40	58	66
Max capacity (kN)		8	25	50	125
<p>Max capacity, compression load (kN) for different lengths of stroke at threefold safetyfactor against breaking (Euler I)</p> <p>Free load</p>  <p>Fig. 36</p>	Free spindle length (m)				
	0.2				
	0.3	6.6	18		
	0.4	3.7	10		
	0.5	(2.4)	6.6	40	119
	0.6		(4.6)	28	83
	0.7			20	61
	0.8			16	46
	0.9			(12)	37
	1.0			(10)	30
	1.25				(19)
	1.50				
	1.75				
	2.00				
	2.25				
	2.50				

Compression load table BDK-BDKL Euler II

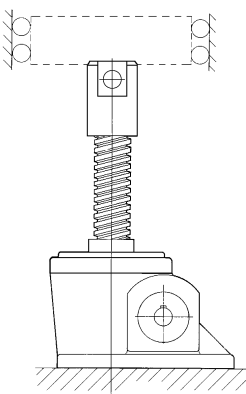
Size		27	40	58	66
Max capacity (kN)		8	25	50	125
<p>Max capacity, compression load (kN) for different lengths of stroke at threefold safetyfactor against breaking (Euler II)</p> <p>Guided load</p>  <p>Fig. 37</p>	Free spindle length (m)				
	0.2				
	0.3				
	0.4				
	0.5				
	0.6	6.6	18		
	0.7	4.9	13		
	0.8	3.7	10		
	0.9	(3.0)	8.1		
	1.0	(2.4)	6.6	40	119
	1.25		(4.2)	26	76
	1.50			18	53
	1.75			(13)	39
	2.00			(10)	30
	2.25				(24)
	2.50				(19)

Rotating screw

The values given in brackets must only be used at low lifting speed and concentric load on the lifting screws.

Compression load table BDK-BDKL Euler III

Size	27	40	58	66
Max capacity (kN)	8	25	50	125
Max capacity, compression load (kN) for different lengths of stroke at threefold safetyfactor against breaking (Euler III)	0.2			
	0.3			
	0.4			
	0.5			
	0.6			
	0.7			
	0.8	7.7	21	
	0.9	5.9	16	
	1.0	4.8	13	
	1.25	(3.0)	8.4	
	1.50		5.8	36
	1.75		(4.3)	26
	2.00			20
	2.25			16
	2.50			(13)
3.00				
3.50				

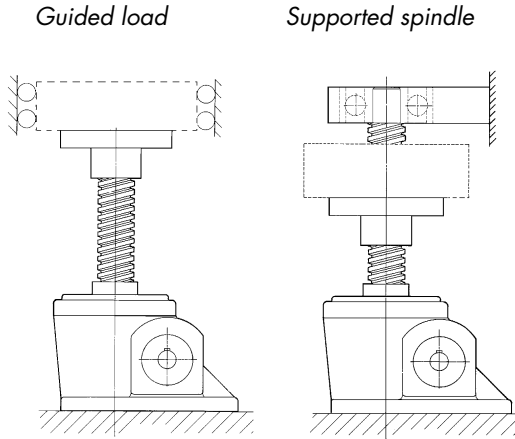

Fig. 38

The values given in brackets must only be used at low lifting speed and concentric load on the lifting screws.

Power ratings BDK - BDKL

Power ratings for BDK-BDKL at 60% ED/10 min or max 30% ED/hour at ambient temperature +25°C.

Note: Power ratings indicate running power. Additional power will be required on start. See "Selection of jacks".

- n = input speed (rpm)
- v = lifting speed (mm/min)
- η_d = running efficiency
- L = low ratio
- T = input torque (Nm)
- P = input power (kW)
- i = ratio of worm gear set

BDK 27 L (i = 9) 20 x 5

n rpm	v mm/min	η_d	8 kN		6 kN		4 kN		2 kN		1 kN	
			Nm	kW	Nm	kW	Nm	kW	Nm	kW	Nm	kW
2900	1611	.46	1.5	.46	1.2	.36	.87	.27	.56	.17	.40	.12
1750	972	.45	1.5	.28	1.2	.22	.87	.16	.56	.10	.40	.07
1500	833	.45	1.6	.25	1.3	.20	.92	.14	.58	.09	.41	.06
1000	556	.44	1.6	.17	1.3	.13	.92	.10	.58	.06	.41	.05
750	417	.43	1.6	.13	1.3	.10	.92	.07	.58	.05	.41	.05
500	278	.42	1.7	.09	1.3	.07	.97	.05	.61	.05	.42	.05
400	222	.41	1.7	.07	1.3	.06	.97	.05	.61	.05	.42	.05
300	167	.40	1.7	.05	1.3	.05	.97	.05	.61	.05	.42	.05
200	111	.39	1.8	.05	1.4	.05	1.0	.05	.63	.05	.44	.05
100	56	.37	1.9	.05	1.5	.05	1.1	.05	.66	.05	.45	.05
50	28	.35	2.0	.05	1.6	.05	1.1	.05	.68	.05	.46	.05

BDK 40 L (i = 7) 25 x 10

n rpm	v mm/min	η_d	25 kN		20 kN		15 kN		10 kN		7.5 kN		5 kN		2.5 kN	
			Nm	kW	Nm	kW	Nm	kW	Nm	kW	Nm	kW	Nm	kW	Nm	kW
2700	3857	.56					6.0	1.7	4.1	1.2	3.2	.90	2.2	.63	1.3	.36
1750	2500	.55					6.1	1.1	4.2	.75	3.2	.58	2.3	.41	1.3	.24
1500	2143	.55					6.1	.96	4.2	.66	3.2	.51	2.3	.36	1.3	.20
1000	1429	.52			8.6	.90	6.5	.68	4.5	.47	3.4	.36	2.4	.25	1.4	.14
750	1071	.52			8.7	.69	6.6	.52	4.5	.36	3.5	.28	2.4	.19	1.4	.11
500	714	.51	11	.58	8.9	.47	6.8	.36	4.6	.24	3.6	.19	2.5	.13	1.4	.07
400	571	.50	11	.47	9.1	.38	6.9	.29	4.7	.20	3.6	.15	2.5	.11	1.4	.06
300	429	.49	12	.36	9.3	.29	7.0	.22	4.8	.15	3.7	.12	2.6	.08	1.5	.05
200	286	.48	12	.25	9.5	.20	7.2	.15	4.9	.10	3.8	.08	2.6	.06	1.5	.05
100	143	.46	12	.13	9.9	.10	7.5	.08	5.1	.05	3.9	.05	2.7	.05	1.5	.05
50	71	.44	13	.07	10	.06	7.9	.05	5.4	.05	4.1	.05	2.9	.05	1.6	.05

BDK 58 L (i = 6.75) 40 x 10

n rpm	v mm/min	η_d	50 kN		40 kN		30 kN		25 kN		20 kN		15 kN		10 kN	
			Nm	kW	Nm	kW	Nm	kW	Nm	kW	Nm	kW	Nm	kW	Nm	kW
2000	2963	.58					12	2.5	10	2.1	8.2	1.7	6.3	1.3	4.4	.91
1750	2593	.58					12	2.2	10	1.8	8.2	1.5	6.3	1.1	4.4	.80
1500	2222	.58					12	1.9	10	1.6	8.3	1.3	6.4	.99	4.4	.69
1000	1481	.55			17	1.8	13	1.4	11	1.1	8.7	.93	6.7	.71	4.6	.49
750	1111	.55			17	1.3	13	.99	11	.83	8.8	.67	6.7	.51	4.7	.36
500	741	.52	23	1.2	18	.97	14	.73	12	.61	9.3	.50	7.1	.38	4.9	.26
400	593	.51	23	.95	18	.76	14	.58	12	.49	9.4	.39	7.2	.30	5.0	.21
300	444	.51	23	.72	19	.58	14	.44	12	.37	9.5	.30	7.3	.23	5.0	.16
200	296	.49	24	.49	19	.39	14	.30	12	.25	9.7	.20	7.4	.15	5.1	.11
100	148	.48	25	.26	20	.21	15	.16	13	.13	10	.11	7.7	.08	5.3	.06
50	74	.46	26	.13	21	.10	16	.08	13	.07	11	.05	8.0	.05	5.5	.05

BDK 66 L (i = 7) 50 x 10

n rpm	v mm/min	η_d	125 kN		100 kN		75 kN		50 kN		25 kN		20 kN		10 kN	
			Nm	kW	Nm	kW	Nm	kW	Nm	kW	Nm	kW	Nm	kW	Nm	kW
1750	2500	.56							20	3.7	10	1.9	8.4	1.5	4.5	.83
1500	2143	.56							20	3.2	10	1.6	8.4	1.3	4.5	.72
1000	1429	.55							21	2.1	11	1.1	8.6	.88	4.6	.47
750	1071	.52					32	2.5	22	1.7	11	.86	9.1	.70	4.8	.37
500	714	.51					33	1.7	22	1.1	11	.59	9.2	.48	4.9	.25
300	429	.50			45	1.4	34	1.1	23	.71	12	.36	9.4	.30	5.0	.16
250	357	.50			45	1.2	34	.90	23	.61	12	.31	9.5	.25	5.0	.13
200	286	.49			46	.95	34	.72	23	.48	12	.25	9.6	.20	5.1	.11
150	214	.49	58	.91	46	.73	35	.55	23	.37	12	.19	9.7	.15	5.2	.08
125	179	.48	58	.76	47	.61	35	.46	24	.31	12	.16	9.8	.13	5.2	.07
100	143	.48	59	.62	47	.50	36	.37	24	.25	12	.13	10	.10	5.3	.06
50	71	.46	62	.32	49	.26	37	.19	25	.13	13	.07	10	.05	5.5	.05

Intermittance factor (ED) BDK/BDKL

Intermittance factor, if the ED is other than 30%/hour the running power (P_d) must be adjusted according to diagram which is calculated by following formula:

$$P_{ED} = \frac{30\%}{ED\%} \times P_{max}$$

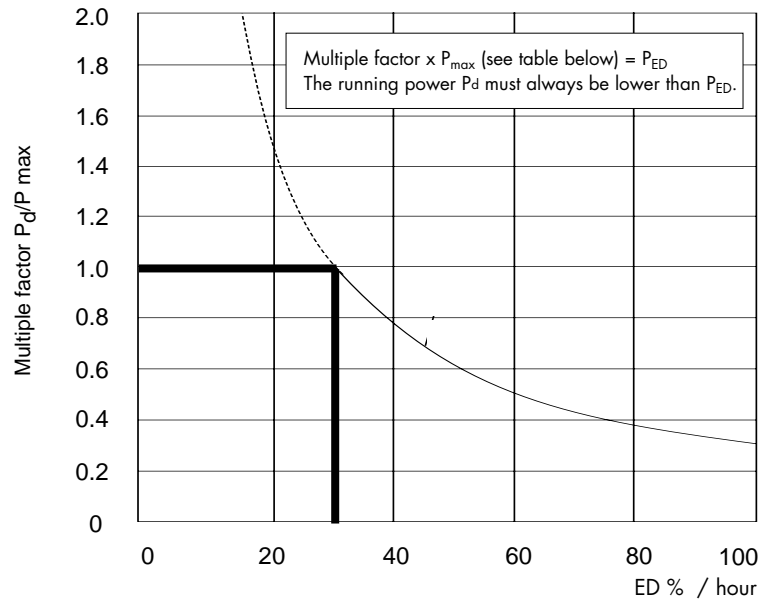

Critical travelling nut speed

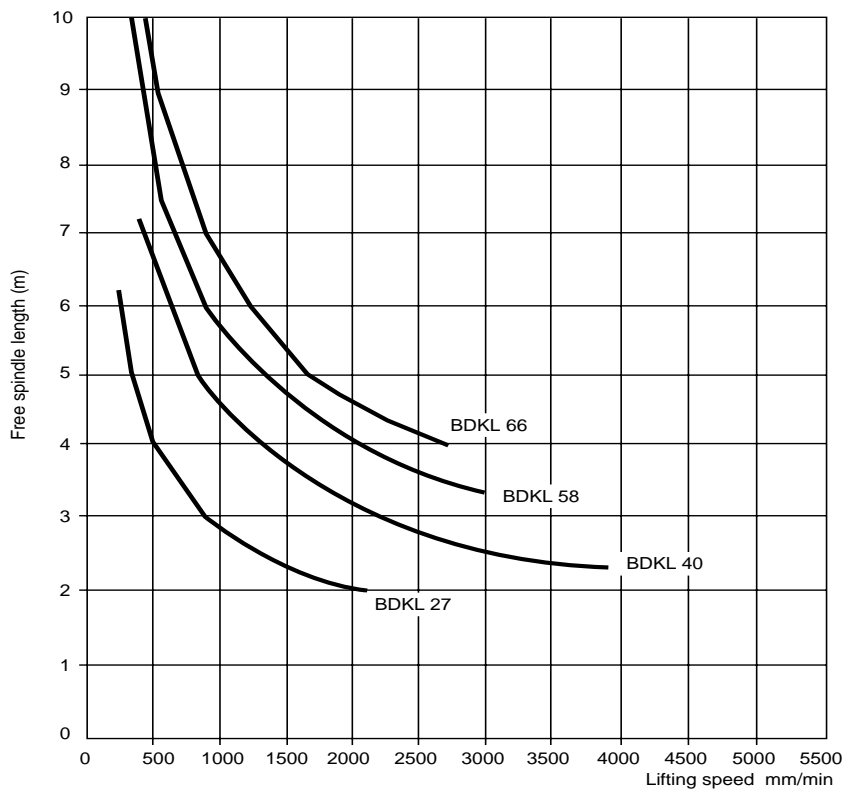

Max permissible speed V mm/min with grease lubrication

BDK / BDKL	Ratio L
27	2100
40	3900
58	3000
66	2700

Lifetime of ball screws

The nominal lifetime is reached by 90% of the ball screws before the running surfaces show any sign of fatigue. 50% of the ball screws reach a lifetime which is 5 times their nominal lifetime.

Lifetime in running metres x 10³

Size	Max load (kN)	100% of max load (km)	75% of max load (km)	50% of max load (km)
27	8	15.6	37.1	125.1
40	25	5.8	13.7	46.1
58	50	10.8	25.6	86.4
66	125	1.5	3.5	11.8

Dimensions BDK 27

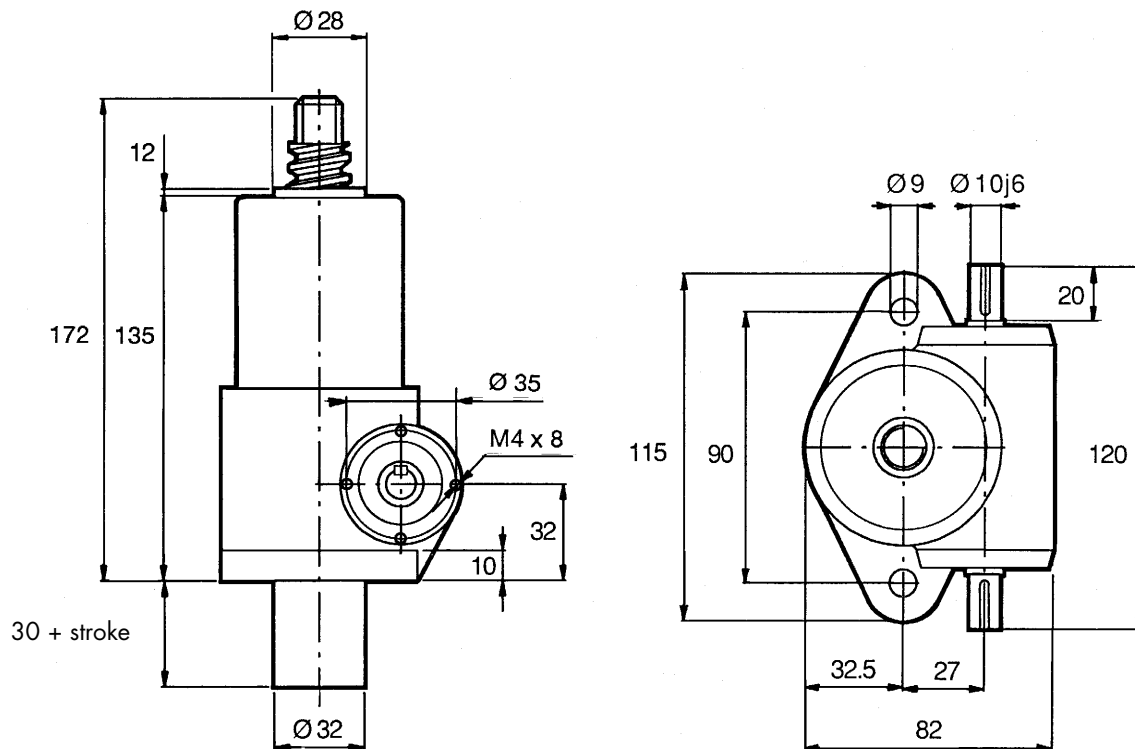

Keyway BS 4235

Fig. 39

Dimensions BDK 40-66

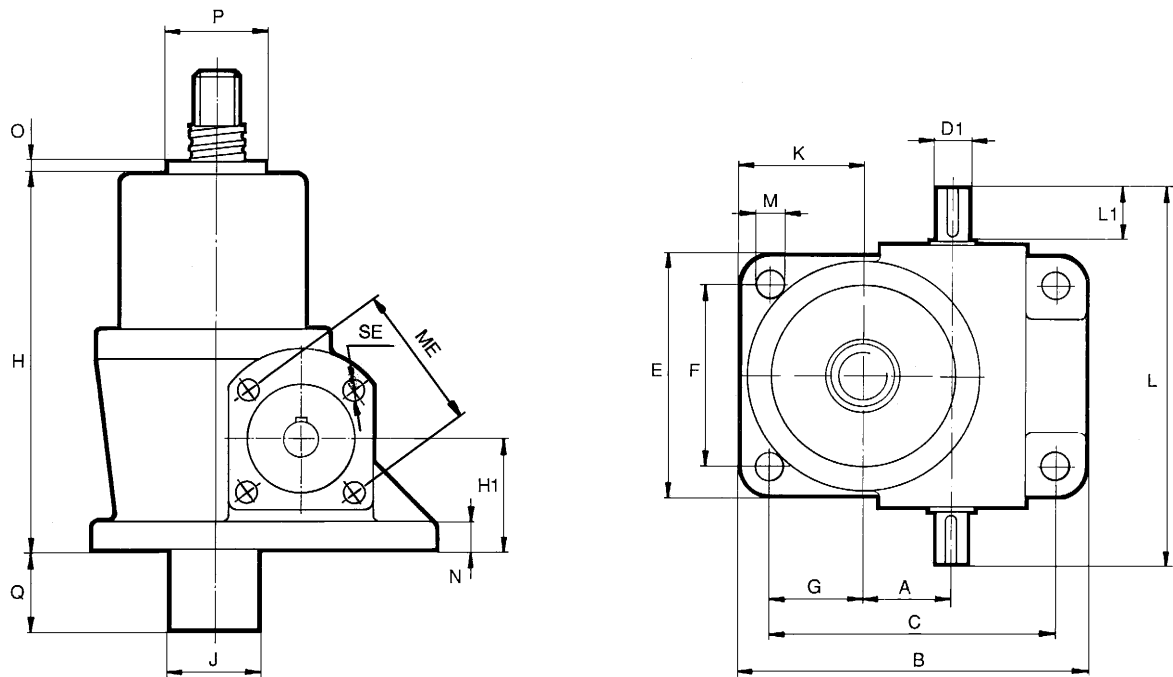

Fig. 40

Size	40	58	66
A	40	58	66
B	156	196	222
C	130	158	178
$\varnothing D1_{j6}$	14	19	24
E	110	170	190
F	84	134	146
G	42	40	51
H	190	265	318
H1	50	55	68
$\varnothing J$	45	55	75
K	55	60	73
L	172	237	268
L1	25	35	40
$\varnothing M$	13	18	21
N	12	12	16
O	15	15	15
$\varnothing P$	40	50	70
Q	35 + Stroke	35 + Stroke	35 + Stroke
SE	M8 x 12	M8 x 12	-
ME	65	80	-

Keyway BS 4235

Dimensions BDK 27-66 end execution 1, 2, 3

Execution 1

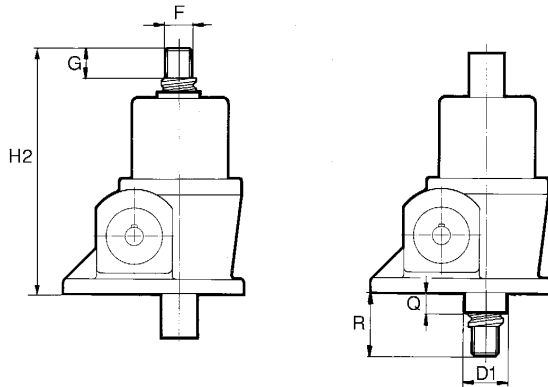
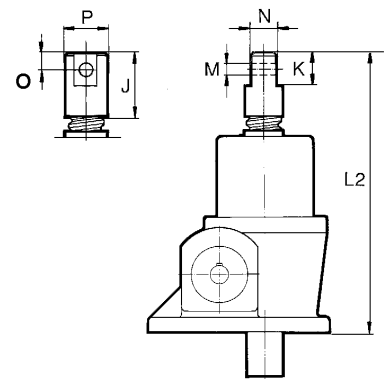

Fig. 41

Execution 3



Execution 2

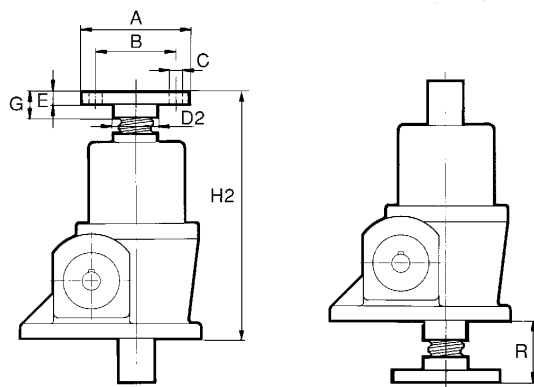

Fig. 42

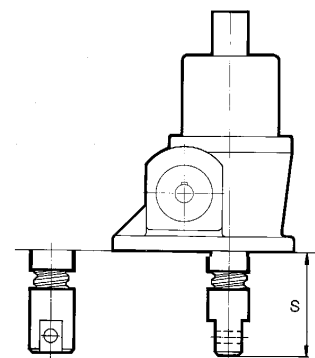

Fig. 43

Size	27	40	58	66
Ø A	65	92	122	150
Ø B	50	65	90	110
Ø C	4x7	4x14	4x18	4x 21
Ø D1	28	40	50	70
Ø D2	30	40	55	70
E	8	12	16	20
F	M14x2	M20x1.5	M30x2	M40x3
G	20	25	36	50
H2	172	235	321	388
J	55	75	100	125
K	25	35	50	60
L2	207	285	385	463
Ø MH11	12	18	25	30
N	20	25	35	45
O	12.5	17.5	25	30
Ø P	30	40	55	70
Q	12	15	15	15
R	37	45	56	70
S	72	95	120	145

Dimensions with bellows BDK 27-66

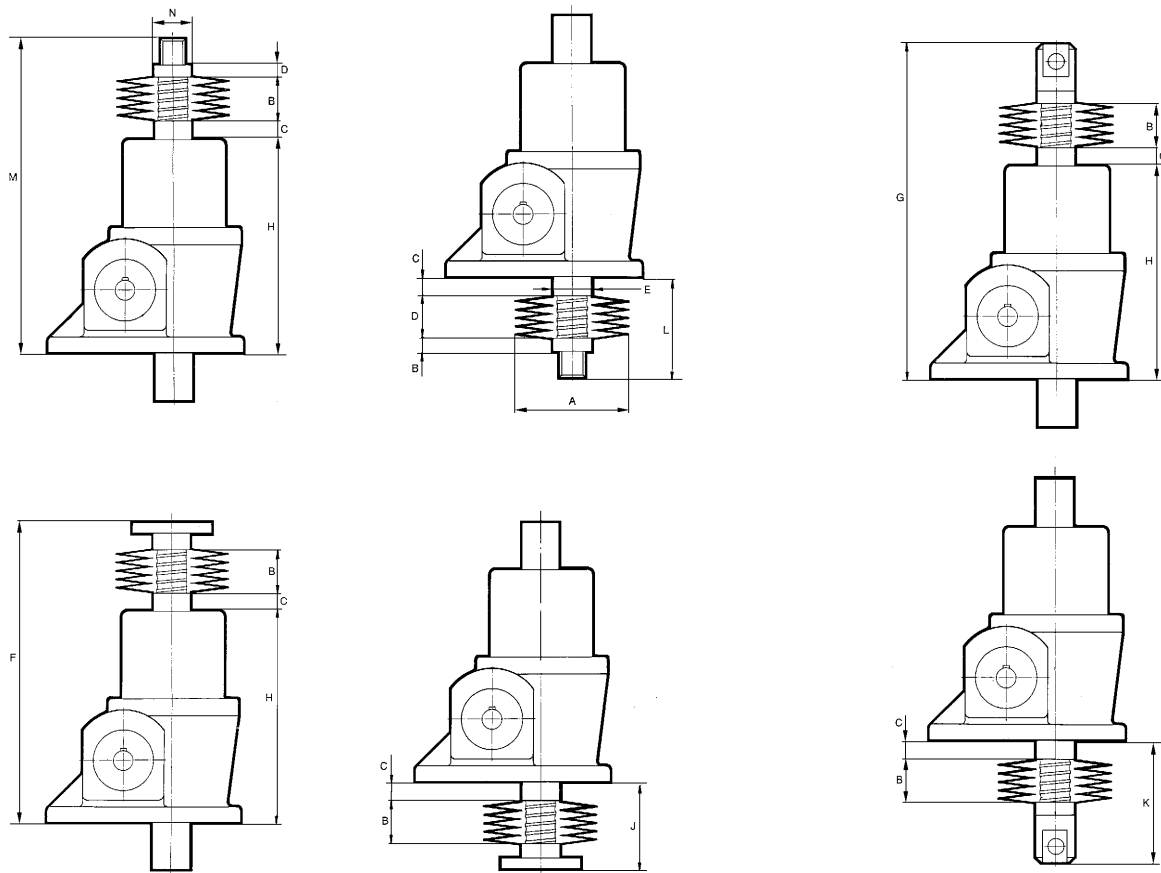

Fig. 44

Size	27	40	58	66
Ø A	95	115	130	150
B min	5	5	5	5
B max	0.05 x Stroke	0.05 x Stroke	0.05 x Stroke	0.05 x Stroke
C	12	15	15	15
D	15	15	15	15
E*	28	40	50	70
F	172 + B	235 + B	321 + B	388 + B
G	207 + B	285 + B	385 + B	463 + B
H	135	190	265	318
J	37 + B	45 + B	56 + B	70 + B
K	72 + B	95 + B	120 + B	145 + B
L	52 + B	60 + B	71 + B	85 + B
M	187 + B	250 + B	336 + B	403 + B
N	30	40	55	70

*Hole for hose clamp Ø E + 30

Dimensions BDKL 27-66

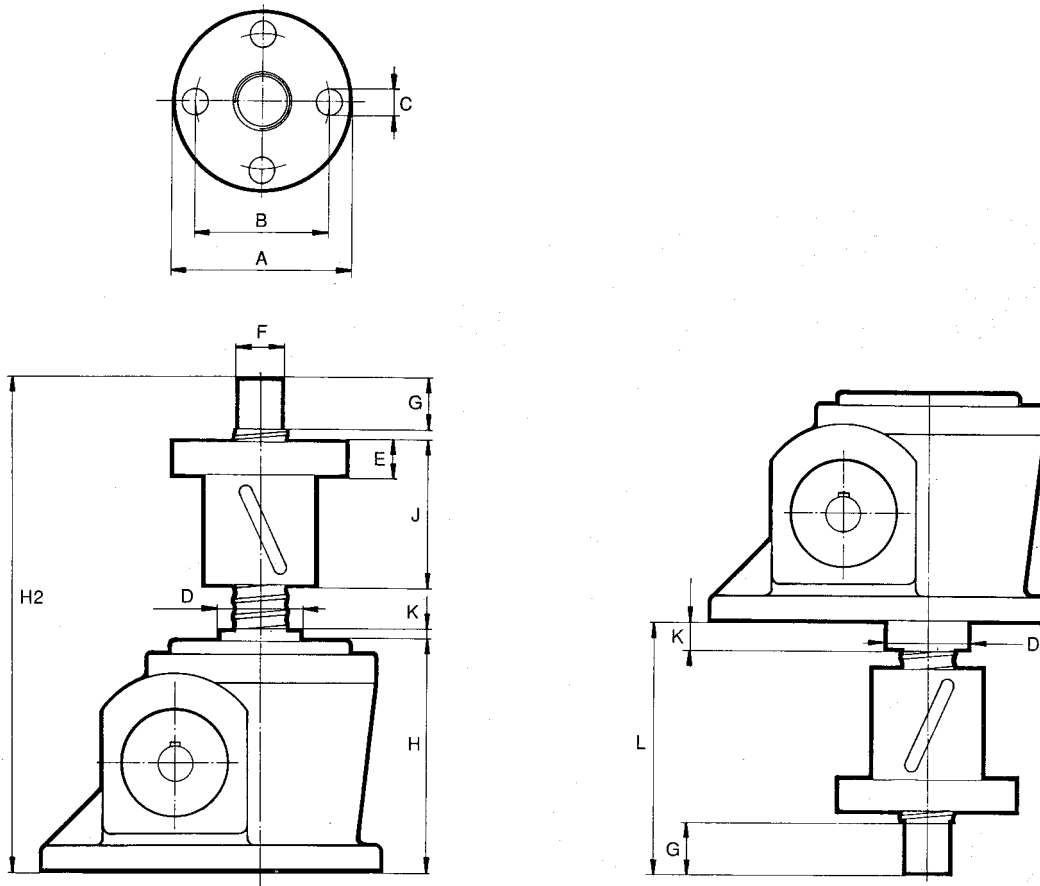

Fig. 45

Size	27	40	58	66
Ø A	83	72	117	137
Ø B	70	57	91	108
Ø C	4 x 7	6 x 9	8 x 18	8 x 18
Ø D	28	40	50	70
E	17	18	28	30
Ø F h7	12	20	30	40
G	20	30	40	60
H	70	105	130	157
H 2	185 + Stroke	250 + Stroke	340 + Stroke	420 + Stroke
J	57	88	114	136
K	12	15	15	15
L	121 + Stroke	150 + Stroke	230 + Stroke	284 + Stroke

IEC Motorflange

BD86 - BD200 consult Benzlers.

Size	Motorsize	Ø A		B	C		Ø H		Ø K		Ø P	Q		R	SE	ME	NE	D	E /B5	F /B5	G
		B14	B5		B14	B5	B14	B5	B14	B5		B14	B5								
BD27	63	90	-		100.5	-	75		60		11	6		3.5					23	17.5	62
BD27	71	105	-	60	111.5	-	85		70		14	7		4	M4x8	35	28	38.5	30	21.5	73
BD27	80	120	-		119	-	100		80		19	7		4					40	19	80.5
BD40	63	92	140		112	112	75	115	60	95	11	6	6	3.5					23	3	52
BD40	71	102	160	86	118	118	85	130	70	110	14	7	7	4	M8x12	65	47	60	30	1/2	57/58
BD40	80	118	200		128	128	100	165	80	130	19	7	11.5	4					40	2	68
BD40	90	140	200		138	138	115	165	95	130	24	9	11.5	4					50	2	78
BD58	71	108	160		151	151	85	130	70	110	14	7	7	4					30	2.5	69
BD58	80	118	200		161	171	100	165	80	130	19	7	11.5	4					40	2.5/	89
BD58	90	140	200	118.5	171	171	115	165	95	130	24	9	11.5	4	M8x12	80	62	82	50	2.5	89
BD58	100/112	160	250		181.5	181.5	130	215	110	180	28	9	14	5					60	3	99.5
BD66	71	108	160		171	171	85	130	70	110	14	7	7	4					30	7	79
BD66	80	118	200	134	181	191	100	165	80	130	19	7	11.5	4	M8x12	80	62	92	40	7	89
BD66	90	140	200		191	191	115	165	95	130	24	9	11.5	4					50	7	99
BD66	100/112	160	250		201.5	201.5	130	215	110	180	28	9	14	5					60	7.5	109

Bigger jacksize motorflanges are available on request.
All IEC-motors are accepted.
Other motors on request.

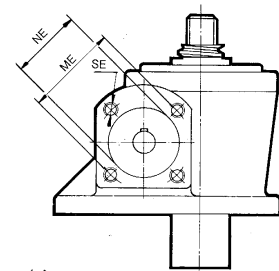
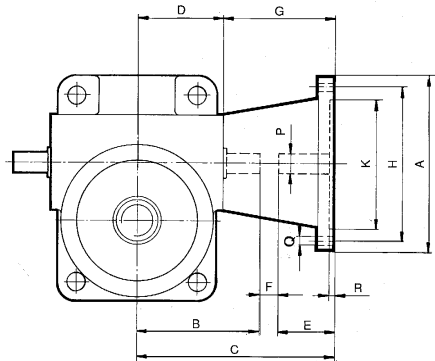

Fig. 46

Trunnion

Single and double trunnion available

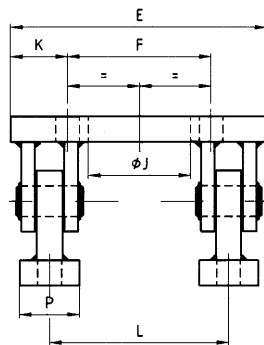
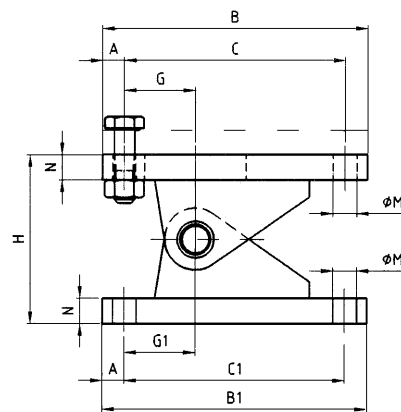

Fig. 47



Size	A	B	B1	C	C1	E	F	G	G1	H	J	K	L	M	N	P
40	13	156	156	130	130	140	84	42	42	80	60	28	100	14	13	30
58	19	196	205	158	165	170	134	40	47	105	80	18	125	18	16	35
66	22	222	234	178	190	250	146	51	63	150	95	52	170	22	22	70
86	25	300	300	250	250	300	170	85	85	170	125	65	210	26	28	70
100	35	350	350	280	280	350	190	95	95	205	155	80	250	33	34	80
125	40	460	460	380	380	440	220	140	140	260	200	110	320	39	47	90

Combination Screw jack with other Benzler products for low lifting speeds consult Benzlers

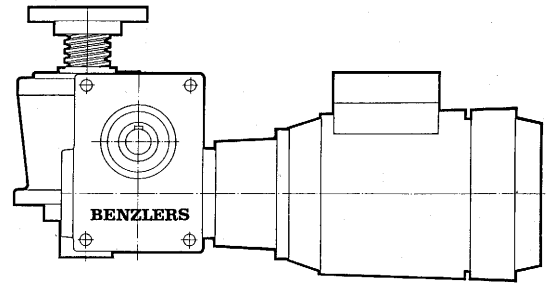
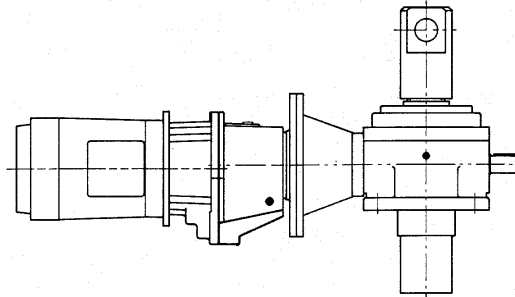

Fig. 48

Example of arrangements

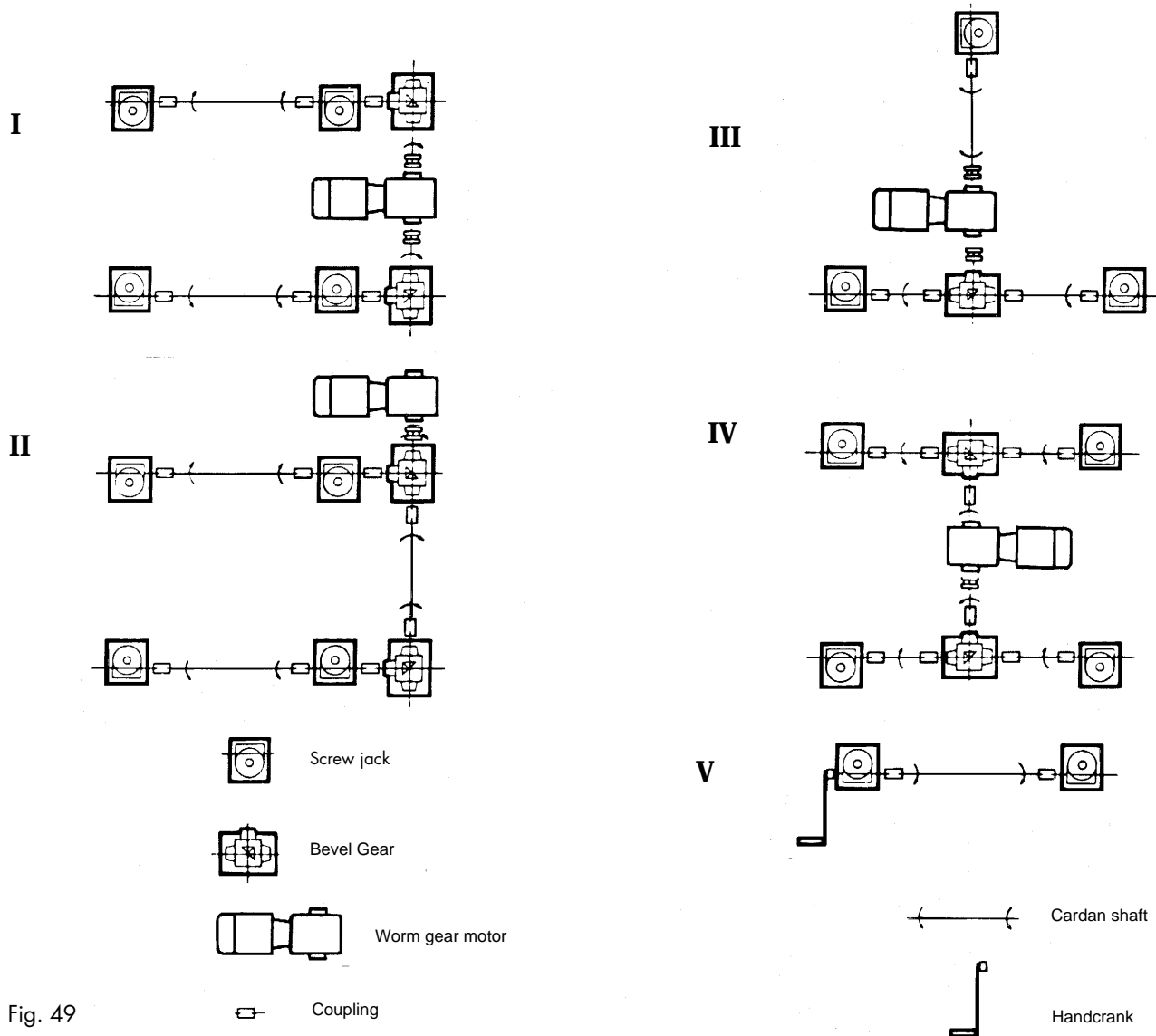

Fig. 49

Benzler Universal Joint shaft

Type X-G

Universal joint shafts for spanning any distance and for compensating for larger radial offset misalignments. The element type X is torsionally very stiff, free from play, but has bending elasticity and is axially and angularly flexible. Moreover, it is oil-resistant and withstands temperatures up to 150° C.

Selection of Universal Joint Shafts:

Torque capacity is in accordance with the table bellow. Permissible angular misalignment is as shown in table and diagram below. The maximum permissible length for the centre part is dependant on the speed and can be found from diagram on page 48.

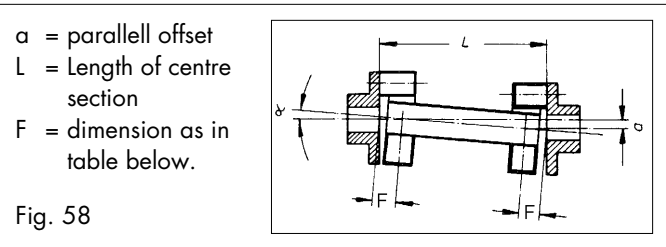

Permissible Shaft Misalignment

Types	Angular Degree	Parallel Offset mm (a)	Axial mm
X-G	1°	$\tan \alpha (L-2F)$	± 1

* Applies for 1500 R:P:M.; for other speeds refer to diagram below.

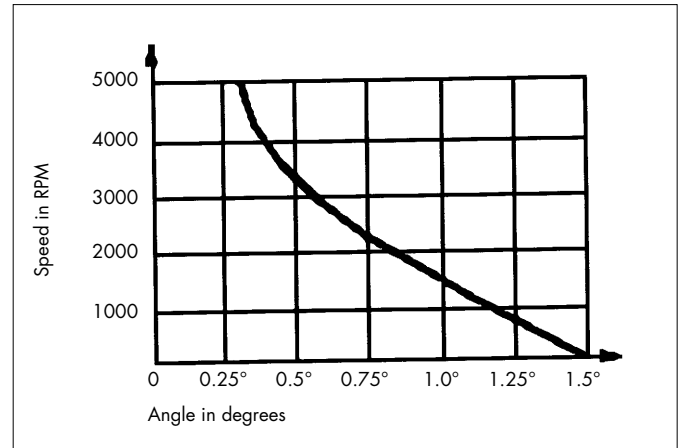

Dimensions

Size	A	B	d ₁		d ₂	d ₃	F	L ₁	M	N ₁	R	T _K /Division
			min	max								
1 X	18	7	8	25	56	57	12	24	M6	36	30	44/2x180°
2 X	24	8	12	38	85	88	14	28	M8	55	40	68/2x180°
4 X	25	8	15	45	100	100	14,5	30	M8	65	45	80/3x120°
8 X	30	10	18	55	120	125	17	42	M10	80	60	100/3x120°
16 X	35	12	20	70	150	155	21	50	M12	100	70	125/3x120°
25 X	40	14	20	85	170	175	23	55	M14	115	85	140/3x120°
30 X	50	16	25	100	200	205	30	66	M16	140	100	165/3x120°

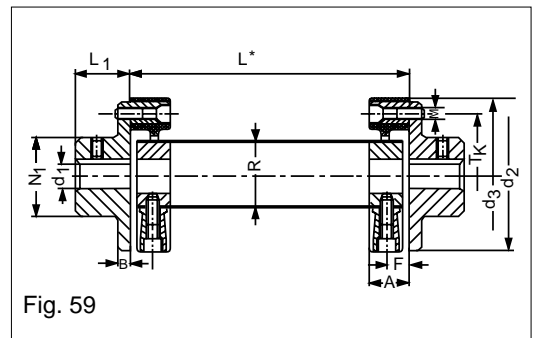

* Dimensions L stands for any non standard lengths. Always state the required dimension in enquiries and orders.

Sizes

The shafts are available in 7 sizes for nominal torques from 10 to 550 Nm with a single element or up to 1100 Nm with two elements connected in tandem. Coupling selection should always be based on nominal torque rating.

Permissible shaft length

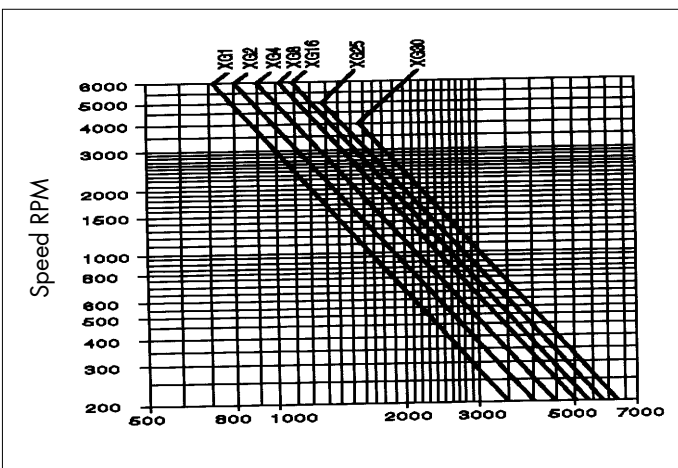

Permissible Torques and Speeds

Size	Nominal torque T _K Nm	Max torque T _{Kmax} Nm	Max speed n _{max} RPM
1	10	25	10000
2	30	60	10000
4	60	120	8000
8	120	280	7000
16	240	560	6000
25	370	800	5000
30	550	1400	4500

Bevel gears

Benzler recommend two types of bevel gears to be used in screw jack arrangement.

1. DZ-Range

For smaller loads and lower speeds we recommend the DZ-range.

- Sand cast aluminium housing
- Hardened, straight bevel gears, ratio 1:1 or 2:1
- DZ1: Lubricated for life with grease.

DZ2-3-4: Lubricated with oil to be changed every 1000 hour.

- All mounting positions possible.
- Shaft dimensions acc. to ISO, keyways acc. to ISO, DZ1 have no keyways.
- Lifetime approx 2 000 hours

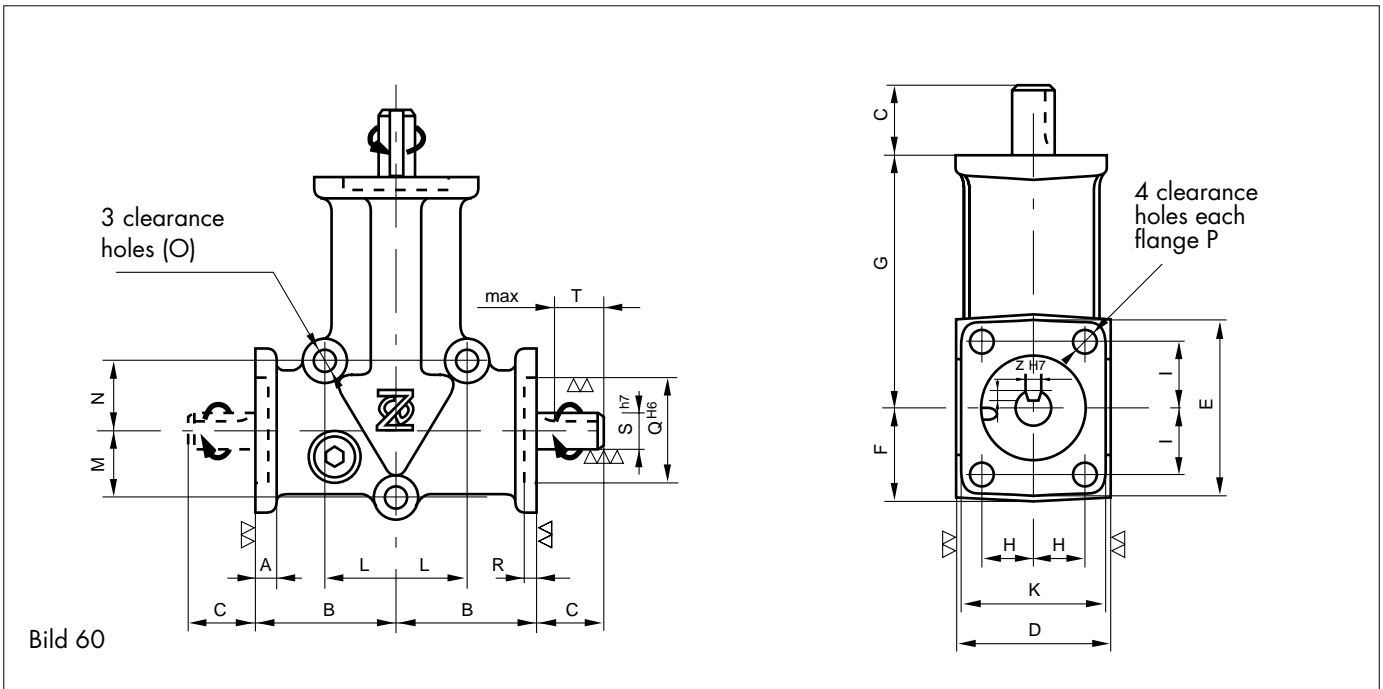

Type	Shaft S	A	B	C	D	E	F	G	H	K	I	L	M	N	O	P	Q	R	S	T	U	Z
DZ 1	3	5	34	15	33	40	21	60	11	32	15	16	16	16	5.2	4.2	22	2.5	8			
DZ 2	3	7	52	35	52	66	33	90	18	50	26	24	24	24	8.2	6.2	35	5	15	27	3	5
DZ 3	3	8	75	50	76	96	48	140	27	74	38	38	38	38	8.2	8.2	55	3.5	20	40	3.5	6
DZ 4	3	13	80	70	100	98	55	150	38	98	38	45	45	70	12.3	10.3	65	3.5	25	60	4	8

Input speed n_1 rpm	Ratio	Output speed n_2 rpm	DZ1		DZ2		DZ3		DZ4	
			Input power P_1 kW	Output torque T_2 Nm	Input power P_1 kW	Output torque T_2 Nm	Input power P_1 kW	Output torque T_2 Nm	Input power P_1 kW	Output torque T_2 Nm
50	1:1	50	0.02	3.5	0.07	12.3	0.25	47	0.32	62
50	2:1	25	0.01	2.4	0.02	7.3	0.08	29	0.14	53
200	1:1	200	0.07	3.3	0.24	11.4	0.92	44	1.14	55
200	2:1	100	0.01	1.4	0.07	6.4	0.27	26	0.48	46
600	1:1	600	0.18	2.9	0.65	10.3	2.40	38	2.90	46
600	2:1	300	0.04	1.3	0.18	5.8	0.75	24	1.33	42
1000	1:1	1000	0.27	2.6	0.98	9.3	3.58	34	4.25	41
1000	2:1	500	0.07	1.2	0.28	5.3	1.08	21	1.89	36
1500	1:1	1500	0.37	2.3	1.36	8.7	4.64	29	5.87	37
1500	2:1	750	0.10	1.2	0.42	5.2	1.55	20	2.74	35
3000	1:1	3000	0.62	2.0	2.51	8.0	8.73	28	10.75	34
3000	2:1	1500	0.14	0.9	0.60	3.8	2.78	18	4.56	29

Bevel gears

2. C-range

For larger loads and higher speeds we recommend the C-range.

- High resistance aluminium alloy housing.
- Hardened, tempered and lapped spiral bevel gears. Ratio 1:1 or 2:1.
- Lubricated with synthetic oil. (Not filled at delivery).
- All mounting positions are possible without modification of fixing.
- Oil sealing to IP 43
- Lifetime approx 6000 hours.
- Rotation in two directions.

Bevel gears with other ratio and higher power ratings available on request.

Shaft arrangements

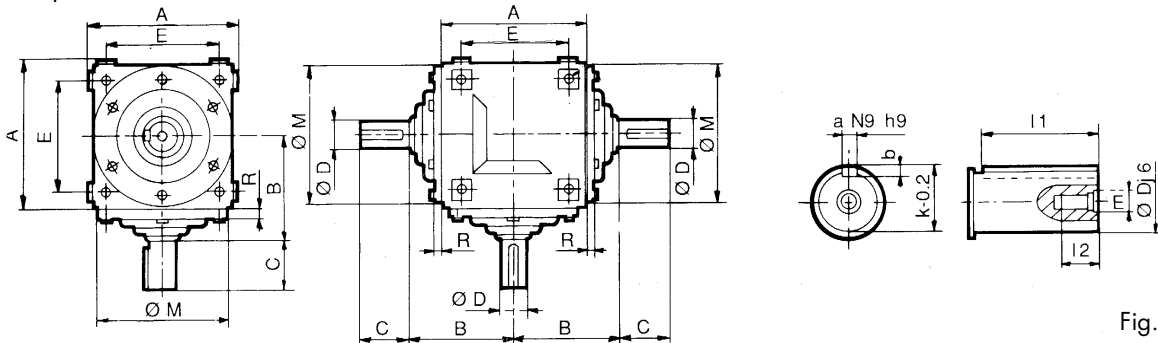
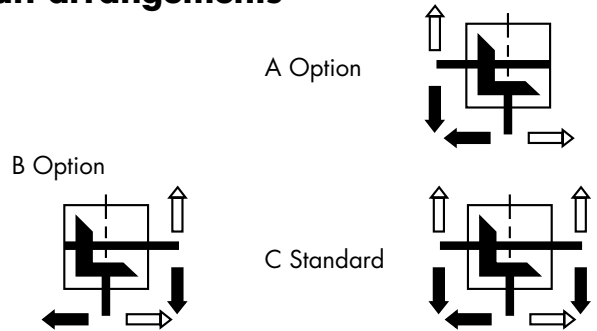
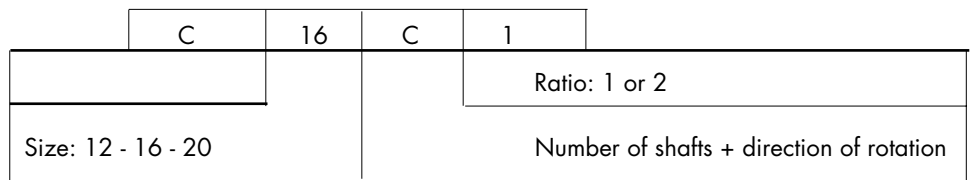

Fig. 61

Type	A	B	C	Dj6	E	F	Mf7	R	Kg	Shaft key as per				Tapped hole		
										Ø Dj6	DIN 6885 ah9	NF 22 1 75 b	BS 4236 k-0.2 l1	m	l2	
C.12	124	97	50	25	95	M8 x 14	116	10	6	25	8	7	28	45	M8	15
C.16	160	115	60	30	120	M10 x 20	150	12	12	30	8	7	33	55	M8	15
C.20	200	140	75	40	150	M12 x 25	190	13	22	40	12	8	43	70	M10	19

Example of coding



Admissible radial loads on shaft end

Size	Input speed (RPM)								
	1500			500			50		
	F1 (N)			F2 (N)			F3 (N)		
Loadfactor Kt = 1.55									
C12	300	650	1800	300	650	1800	750	1150	2350
C16	500	1100	3000	500	1100	3000	1250	2000	3900
C20	1000	1800	5000	1000	1800	5000	2500	3400	6500
Loadfactor Kt = 2									
C12	600	850	2350	600	850	2350	800	1350	2600
C16	950	1400	3800	950	1400	3800	1350	2350	4500
C20	1900	2300	6400	1900	2300	6400	2700	4000	8500

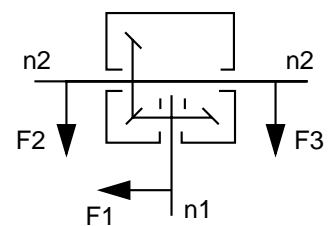

Kt = 1 for direct coupling

Bevel gears

Nominal powers P_n -

Torques on high speed shaft (n_1)

P_n is the nominal power calculated for a life of 6000 hours with service factor $K_a = 1$.

Type	Torques and powers	Speeds on high speed shaft n_1 in RPM														
		10	50	125	250	500	750	1000	1250	1500	1750	2000	2250	2500	2750	3000
		Ratio = 1														
c. 12	Torque - Couple - M.....daNm	19.1	17.2	14.5	13.3	11.4	10.1	9.5	9.1	8.9	8.73	8.6	8	7.6	7.1	6.6
	Power - Pn - PnkW	0.2	0.9	1.9	3.5	6	8	10	12	14	16	18	19	20	20.5	21
c. 16	Torque - Couple - M.....daNm	38.2	30.5	26.7	22.9	20	18.4	17.2	15.6	15.2	13.3	11.9	11	10.3	9.55	
	Power - Pn - PnkW	0.4	1.6	3.5	6	10.5	14.5	18	20.5	24	24.5	25	26	27	27.5	
c. 20	Torque - Couple - M.....daNm	76.4	61.1	53.5	45.8	40	36.9	34.3	32	31.8	28	25.3	23	22.3		
	Power - Pn - PnkW	0.8	3.2	7	12	21	29	36	42	50	51.5	53	54.5	58.5		
		Ratio = 2														
c. 12	Torque - Couple - M.....daNm	9.5	5.7	5.3	4.9	4.7	4	3.8	3.6	3.5	3.2	3.1	2.9	2.8	2.7	2.7
	Power - Pn - PnkW	0.1	0.3	0.7	1.3	2.5	3.2	4	4.7	5.5	6	6.5	7	7.5	8	8.5
c. 16	Torque - Couple - M.....daNm	19.1	15.2	12.9	11.4	9.5	8.9	8.1	7.6	7.3	7	6.9	6.5	6.1	5.7	5.4
	Power - Pn - PnkW	0.2	0.8	1.7	3	5	7	8.5	10	11.5	13	14.5	15.5	16	16.5	17
c. 20	Torque - Couple - M.....daNm	38.2	28.6	26.7	22.9	19.1	17.8	17.1	16	15.6	15.2	14.3	14	13.7	12.6	11.9
	Power - Pn - PnkW	0.4	1.5	3.5	6	10	14	18	21	24.5	28	30	33	36	36.5	37.5

Selection

$$P_m = P_u \times K_a \times K_i \times K_t$$

P_m : Corrected output power (kW)

P_u : Power absorbed by machine (kW)

K_a : Service factor

K_i : Life factor

K_t : Radial load factor

$$\text{Ratio } i = \frac{n_1}{n_2}$$

n_1 = speed on high speed shaft in RPM

n_2 = speed on low speed shaft in RPM

Select the "Cubic" bevel box so:

$$P_n \geq P_m$$

P_n = Nominal power

Service factor K_a

Prime mover	Nominal or infrequent starting	Driven machine Moderate shocks or fairly frequent starting	Heavy shocks or very frequent starting
Electric motor Steam turbine	1.00	1.25	1.50

Life factor K_i

The design life indicate the number of hours running producing normal wear without destruction.

Life required in hours					
100	1000	6000	10000	15000	20000
0.6	0.8	1	1.05	1.2	1.35

Lubrication of Bevel gears

Lubrication by splash:

- All types
- All positions
- Lubrication: recommended oil given on box (bevel box) delivered without oil

Type	C 12	C 16	C 20
Quantity in litres	0.4	0.8	1.5

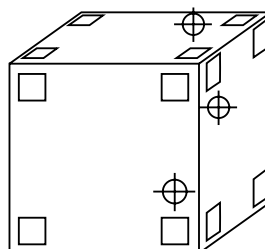

FILLING BREATHER:

breather on top or with elbow on the vertical face.

DRAINING:

on the side or bottom face.

LEVEL:

(by plug): always in the bottom right hand corner.

Telescopic spring protection

- Made of high quality hardened spring steel to dimension shown down
- Very good sealing effect between the coils
- Available also in stainless steel

Di = inside diam

Da = outside diam

DF1 = outside diam of centering flange (Di - 2 mm)

DF2 = inside diam of flange socket (Da + 4 mm)

Lmin = min installation length

Lmax = max installation length

IMPORTANT

When ordering state vertical or horizontal position.

Type	Di ± 1 mm	Da ± 2 mm	L max	L min
BD 27				
SF 30/150/30	30	39	150	30
SF 30/250/30	30	44	250	30
SF 30/350/30	30	49	350	30
SF 30/450/40	30	53	450	40
SF 30/550/40	30	58	550	40
SF 30/650/50	30	55	650	50
SF 30/750/50	30	59	750	50
BD 40				
SF 40/150/30	40	51	150	30
SF 40/250/30	40	56	250	30
SF 40/350/30	40	60	350	30
SF 40/450/40	40	63	450	40
SF 40/550/40	40	68	550	40
SF 40/350/50	40	55	350	50
SF 40/450/50	40	58	450	50
SF 40/550/50	40	61	550	50
SF 40/650/50	40	65	650	50
SF 40/750/50	40	69	750	50
SF 40/450/60	40	55	450	60
SF 40/550/60	40	58	550	60
SF 40/650/60	40	62	650	60
SF 40/750/60	40	66	750	60
SF 40/900/60	40	70	900	60
SF 40/650/75	40	62	650	75
SF 40/750/75	40	66	750	75
SF 40/900/75	40	72	900	75
SF 40/1100/75	40	78	1100	75
SF 40/1300/75	40	84	1300	75
SF 40/1500/75	40	90	1500	75
SF 40/1000/100	40	66	1000	100
SF 40/1200/100	40	70	1200	100
BD 58				
SF 50/150/30	50	63	150	30
SF 50/250/30	50	68	250	30
SF 50/250/50	50	62	250	50
SF 50/350/50	50	66	350	50
SF 50/450/50	50	70	450	50
SF 50/550/50	50	73	550	50
SF 50/550/60	50	68	550	60
SF 50/650/60	50	72	650	60
SF 50/750/60	50	76	750	60
SF 50/750/75	50	78	750	75
SF 50/900/75	50	84	900	75
SF 50/1100/75	50	90	1100	75
SF 50/1100/100	50	75	1100	100
SF 50/1300/100	50	79	1300	100
SF 50/1500/100	50	86	1500	100
SF 50/1800/100	50	94	1800	100

Type	Di ± 1 mm	Da ± 2 mm	L max	L min
BD 66				
SF 60/150/30	60	73	150	30
SF 60/250/30	60	78	250	30
SF 60/250/50	60	71	250	50
SF 60/350/50	60	78	350	50
SF 60/450/50	60	82	450	50
SF 60/550/60	60	81	550	60
SF 60/650/60	60	85	650	60
SF 60/750/60	60	89	750	60
SF 60/750/75	60	89	750	75
SF 60/900/75	60	95	900	75
SF 60/1100/75	60	102	1100	75
SF 60/1100/100	60	90	1100	100
SF 60/1300/100	60	94	1300	100
SF 60/1500/100	60	101	1500	100
SF 60/1800/100	60	109	1800	100
BD 86				
SF 75/150/30	75	92	150	30
SF 75/250/30	75	99	250	30
SF 75/250/50	75	89	250	50
SF 75/350/50	75	94	350	50
SF 75/450/50	75	101	450	50
SF 75/550/60	75	99	550	60
SF 75/650/60	75	103	650	60
SF 75/750/60	75	108	750	60
SF 75/650/75	75	99	650	75
SF 75/750/75	75	104	750	75
SF 75/900/75	75	111	900	75
SF 75/1100/100	75	108	1100	100
SF 75/1300/100	75	112	1300	100
SF 75/1500/100	75	120	1500	100
SF 75/1700/100	75	126	1700	100
SF 75/1500/120	75	115	1500	120
SF 75/1800/120	75	122	1800	120
SF 75/2000/120	75	127	2000	120
SF 75/2200/120	75	132	2200	120
SF 75/2000/150	75	135	2000	150
SF 75/2400/150	75	141	2400	150
SF 75/2800/150	75	145	2800	150
SF 75/2800/180	75	142	2800	180
SF 75/3000/180	75	148	3000	180
SF 75/3250/180	75	156	3250	180
SF 75/3250/200	75	148	3250	200
SF 75/3500/200	75	158	3500	200

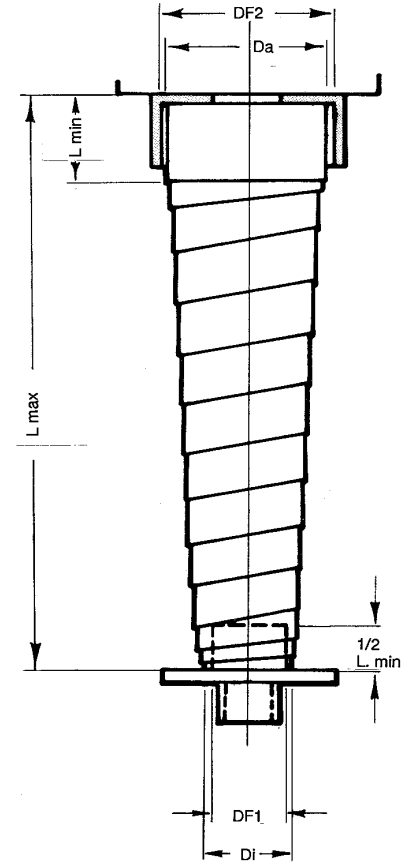

Fig. 51

Type	Di ± 1 mm	Da ± 2 mm	L max	L min
BD 100				
SF 110/250/60	110	131	250	60
SF 110/350/60	110	135	350	60
SF 110/450/60	110	139	450	60
SF 110/350/75	110	130	350	75
SF 110/450/75	110	135	450	75
SF 110/600/75	110	140	600	75
SF 110/650/100	110	129	650	100
SF 110/750/100	110	133	750	100
SF 110/900/100	110	138	900	100
SF 110/1100/120	110	139	1100	120
SF 110/1300/120	110	145	1300	120
SF 110/1500/150	110	155	1500	150
SF 110/1800/150	110	159	1800	150
SF 110/2000/150	110	165	2000	150
SF 110/2000/180	110	159	2000	180
SF 110/2200/180	110	165	2200	180
SF 110/2400/180	110	170	2400	180
SF 110/2400/200	110	162	2400	200
SF 110/2600/200	110	166	2600	200
SF 110/2800/200	110	172	2800	200

Other dimensions available on request.

Lubrication of screw jacks

Type of grease

I. At ambient temperature -30° to +30° C

BP	Energrease LS-EP2
Castrol	Spheerol EPL2
Esso	Beacon EP2
Gulf	Gulflex MP
Mobil	Mobilux EP2
Shell	Alvania EP Grease 2 alt Retinax A
SKF	Alfalub LGEP2
Texaco	Mulfifak EP2

II. At ambient temperature -45°C to -30°C

Mobil Mobil SHC32

III. At ambient temperature +30°C to +60°C

Mobil Mobiltemp SHC100

Sealrings in viton are recommended.

Lubrication intervals

Normal duty < 1 000 mm/min lifting speed:
Every 30 hours of duty

Arduous duty > 1 000 mm/min lifting speed:
Every 10 hours of duty

Renew grease every 400 hours of duty.

Note: On screw jack type BDL and BDKL the lifting screw shall always be lubricated with a thin film of grease.

Screw jack body grease quantity

Type	Grease quantity
BD/BDL/BDKL 27	0.3 kg
BD/BDL/BDKL 40	0.5 kg
BD/BDL/BDKL 58	0.9 kg
BD/BDL/BDKL 66	1.2 kg
BD/BDL 86	1.4 kg
BD/BDL 100	2.5 kg
BD/BDL 125	5.2 kg
BD/BDL 200	15 kg
BDK 27	0.4 kg
BDK 40	0.7 kg
BDK 58	1.7 kg
BDK 66	2.0 kg

Mounting and maintenance instructions

- The jack must not be overloaded.
- The base, on which the jacks are mounted, should be strong enough to carry the max. load and should be rigid enough to prevent swings or turns on the supporting beam of the jack.
- When mounting it is necessary to make sure that the jacks are carefully adjusted and that the connecting shafts and the wormshafts are exactly aligned. The lifting screw or lifting nut must be carefully aligned to prevent radial forces on the lifting screw. When jacks, shafts, gear boxes etc. have been connected it should be possible to turn the main driving shaft by hand (provided that the jacks are unloaded). If there are no signs of seizure or misalignment, the lifting system is now ready for normal operations.
- The screw jacks should have a longer length of stroke than is actually required. Should it be necessary to use total length of stroke, this must be done carefully. It is important that the lifting screws of the jacks are not screwed beyond the closed height (see catalogue), otherwise the worm gear could be severely damaged.
- The lifting screw must not be permitted to collect dust and sand in the threads. If possible the lifting screws should be retracted to the closed position when not in service.
- Maximum wear for types BD and BDL is reached when the thread thickness of the worm wheel or lifting nut is half worn out. Worm wheel and lifting nut must then be replaced. For singlethreaded trapezoid screws the permitted wear is 1/4 of the pitch. The customer should regularly check that normal permitted wear is not exceeded.