

TRANSTECNOTM
THE MODULAR GEARMOTOR

WMP

WMP

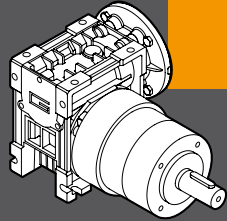

RIDUTTORI COMBINATI
COMBINATION GEARBOXES

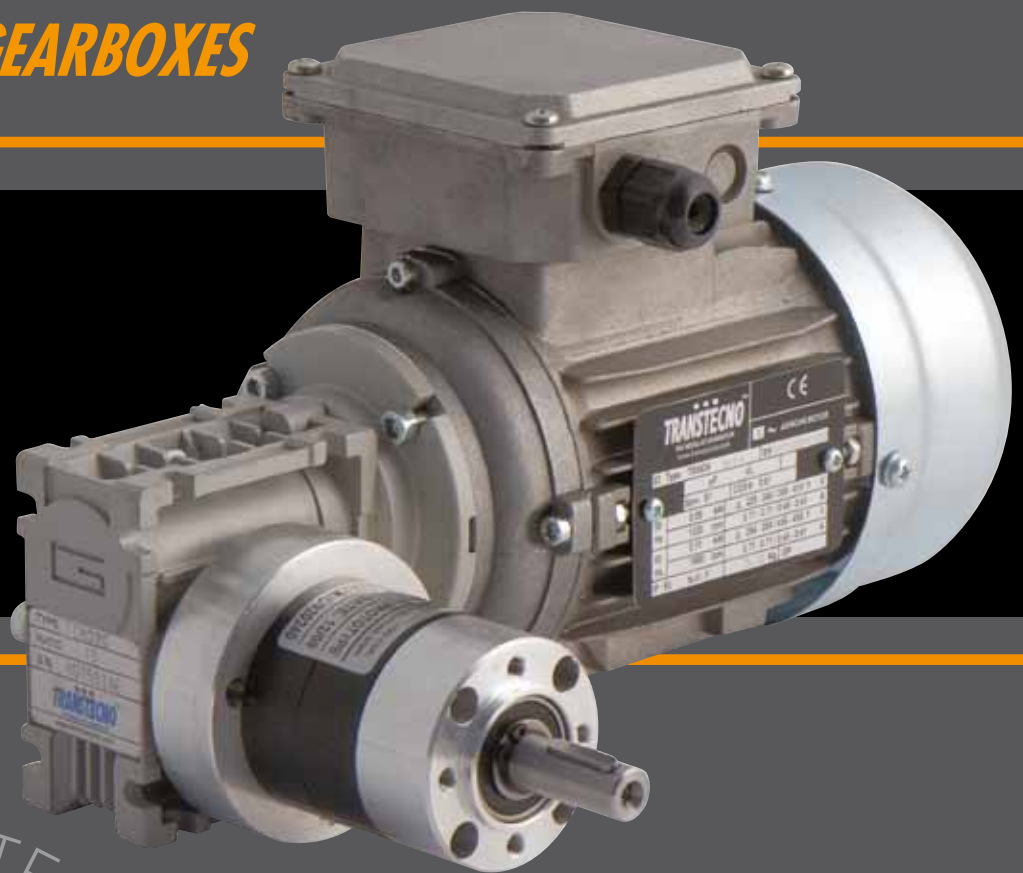

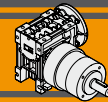

Indice	Index	Pag. Page
Caratteristiche tecniche	<i>Technical features</i>	12
Designazione	<i>Designation</i>	12
Versioni	<i>Versions</i>	12
Simbologia	<i>Symbols</i>	12
Lubrificazione	<i>Lubrication</i>	13
Carichi radiali	<i>Radial loads</i>	13
Rapporti	<i>Ratios</i>	13
Rendimento	<i>Efficiency</i>	13
Dati tecnici	<i>Technical data</i>	14
Dimensioni	<i>Dimensions</i>	15
Opzioni	<i>Options</i>	16

Questa sezione annulla e sostituisce ogni precedente edizione o revisione. Qualora questa sezione non Vi sia giunta in distribuzione controllata, l'aggiornamento dei dati ivi contenuto non è assicurato. **In tal caso la versione più aggiornata è disponibile sul nostro sito internet www.transtecno.com**

*This section replaces any previous edition and revision. If you obtained this catalogue other than through controlled distribution channels, the most up to date content is not guaranteed. **In this case the latest version is available on our web site www.transtecno.com***

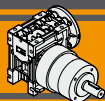

Caratteristiche tecniche

Technical features

L'accoppiamento di un riduttore a vite senza fine con un riduttore epicicloidale consente di ottenere elevati rapporti di riduzione ($i_{max} = 1/18452$) e di disporre di un gruppo autolubrificato compatto, silenzioso e con un'elevata affidabilità.

The coupling of a wormgearbox to a planetary gearbox allows to obtain high reduction ratios ($i_{max} = 1/18452$) and to get a compact, silent, self lubricated with high reliability group.

Designazione

Designation

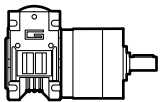
MOTORIDUTTORE / GEARMOTOR						
WMP	026/52	1	CS90	202.5	56B14	VS
Tipo Type	Grandezza Size	Numero stadi epicicloidale Planetary stages number	Versione Version	Rapporto Ratio	IEC	Opzioni Options
	026/52 026/62 030/81	1 2 3	US UD CS80...120 CD80...120	Vedere tabella See tables	120 240 24E	VS

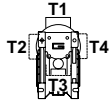
MOTORE CM / CM MOTOR				
0.09kW	4p	3ph	50Hz	T1
Potenza Power	Poli Poles	Fasi Phases	Frequenza Frequency	Pos. morsetti Terminal box pos.
Vedi tabelle See tables	2p 4p 6p 8p	1ph 3ph	50Hz 60Hz	T1 (standard) T2 T3 T4 

Versioni

Versions

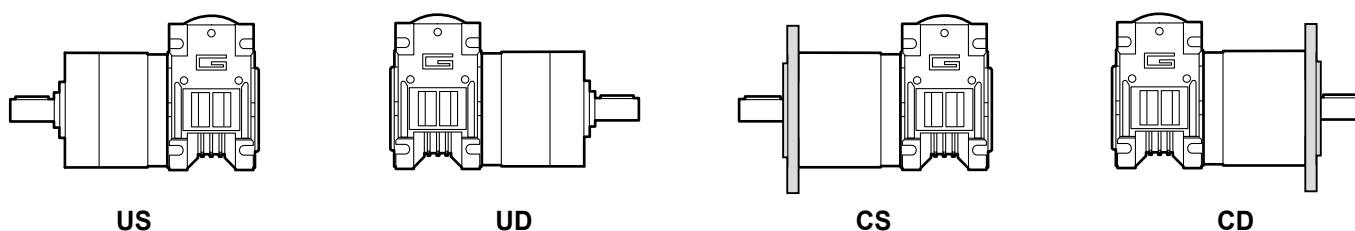

Simbologia

Symbols

- n_1 [min^{-1}] Velocità in ingresso / *Input speed*
- n_2 [min^{-1}] Velocità in uscita / *Output speed*
- i Rapporto di riduzione / *Ratio*
- P_1 [kW] Potenza in entrata / *Input power*
- M_n [Nm] Coppia nominale in uscita del riduttore / *Maximum output torque of the gearbox*
- M_2 [Nm] Coppia in uscita in funzione di P_1 / *Output torque referred to P_1*
- sf Fattore di servizio / *Service factor*
- R_d % Rendimento dinamico / *Dynamic efficiency*
- A_2 [N] Carico assiale ammissibile in uscita / *Permitted output axial load*
- R_2 [N] Carico radiale ammissibile in uscita / *Permitted output radial load*

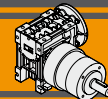

Lubrificazione

Lubrication

I riduttori a vite senza fine della serie CM sono lubrificati a vita con olio sintetico di viscosità 320 e possono essere installati in qualunque posizione di montaggio.

Permanent synthetic oil long-life lubrication allow to use CM wormgearbox range in all mounting position.

I riduttori epicicloidali sono lubrificati in modo permanente, non richiedono quindi ulteriore manutenzione.

Planetary gearboxes are life-time lubricated with grease, therefore they are maintenance free.

Questo gli consente di essere installati praticamente ovunque.

They can be installed in any location.

La temperatura ambiente di funzionamento consentita va da -50°C a + 40°C; per applicazioni particolari possono essere adottate misure per raggiungere livelli di temperatura maggiori.

The environmental temperature range is from -50°C up to +40°C; for special applications, measures can be taken for higher temperature range.

Carichi radiali

Radial loads

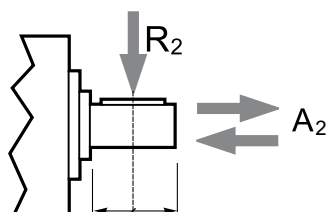

Numero di stadi Stages number	Carichi Radiali R ₂ [N] Radial Load R ₂ [N]		
	P52	P62	P81
1	200	240	400
2	320	360	600
3	450	520	1000

Numero di stadi Stages number	Carichi Assiali A ₂ [N] Axial Load A ₂ [N]		
	P52	P62	P81
1	60	70	80
2	100	100	120
3	150	150	200

Rapporti

Ratios

Motoriduttore Gearmotor	Numero stadi epicicloidale Planetary stages number	Rapporto epicicloidale Planetary ratio	Rapporto vite senza fine Wormgearbox ratio	Rapporto finale Total ratio
WMP 026/052 WMP 026/062 WMP 030/081	1	6.75	10	67.5
			15	101.3
			20	135
			30	202.5
			40	270
			50	337.5
	2	28.93	10	289.3
			15	434.0
			20	578.6
			30	867.9
			40	1157
			50	1447
			60	1736
			60	2098
	34.97	60	2098	
	45.56	60	2734	

Rendimento

Efficiency



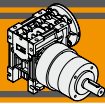

Motoriduttore Gearmotor	n ₁ [min ⁻¹]	Rendimento Efficiency	Rapporto / Ratio															
			67.5	101.3	135	202.5	270	337.5	405	289.3	434	578.6	867.9	1157	1447	1736	2098	2734
WMP026/52...	1400	Rd %	66.4	62.4	59.2	52.8	48.8	45.6	42.4	62.3	58.5	55.5	49.5	45.8	42.8	39.8	39.8	39.8
WMP026/62...			66.4	62.4	59.2	52.8	48.8	45.6	42.4	62.3	58.5	55.5	49.5	45.8	42.8	39.8	39.8	39.8
WMP030/81...			67.2	63.2	60	53.6	49.6	46.4	44	63	59.3	56.3	50.3	46.5	43.5	41.3	41.3	41.3

Rendimento teorico del riduttore dopo il rodaggio
Theoretical efficiency of the gearbox after the first running period

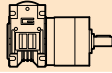

Dati tecnici

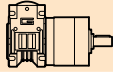
Technical data

P_1 [W]	n_2 [min ⁻¹]	M_2 [Nm]	sf	i			P_1 [W]	n_2 [min ⁻¹]	M_2 [Nm]	sf	i		
0.09							0.12						
56B (1400 min ⁻¹)	20.7	25	1.0	67.5	026/521	B14	63A	20.7	37	2.2	67.5	030/811	63B5/B14
	13.8	25	1.0	101.3			(1400 min ⁻¹)	13.8	52	1.5	101.3		
	10.4	25	1.0	135				10.4	66	1.2	135		63B5/B14
	6.9	25	1.0	202.5				6.9	80	1.0	202.5		63B5/B14
	5.2	25	1.0	270				5.2	80	1.0	270		63B5/B14
	4.8	25	1.0	289.3	026/522	B14		4.8	120	1.0	289.3	030/812	63B5/B14
	4.1	25	1.0	337.5	026/521	B14	0.18						
	3.5	25	1.0	405		B14	63B	20.7	56	1.4	67.5	030/811	63B5/B14
	3.2	25	1.0	434	026/522	B14	(1400 min ⁻¹)	13.8	79	1.0	101.3		
	2.4	25	1.0	578.6		B14		10.4	80	1.0	135		63B5/B14
	1.6	25	1.0	867.9		B14							
	1.2	25	1.0	1157		B14							
	1.0	25	1.0	1447		B14							
	0.8	25	1.0	1736		B14							
	0.7	25	1.0	2098		B14							
	0.5	25	1.0	2734		B14							
	20.7	27	1.5	67.5	026/621	B14							
	13.8	39	1.0	101.3		B14							
	10.4	40	1.0	135		B14							
	6.9	40	1.0	202.5		B14							
	5.2	40	1.0	270		B14							
	4.8	50	1.0	289.3	026/622	B14							
	4.1	40	1.0	337.5	026/621	B14							
	3.5	40	1.0	405		B14							
	3.2	50	1.0	434	026/622	B14							
	2.4	50	1.0	578.6		B14							
	1.6	50	1.0	867.9		B14							
	1.2	50	1.0	1157		B14							
	1.0	50	1.0	1447		B14							
	0.8	50	1.0	1736		B14							
	0.7	50	1.0	2098		B14							
	0.5	50	1.0	2734		B14							
	20.7	28	2.9	67.5	030/811	B5/B14							
	13.8	39	2.0	101.3		B5/B14							
	10.4	49	1.6	135		B5/B14							
	6.9	66	1.2	202.5		B5/B14							
	5.2	80	1.0	270		B5/B14							
	4.8	111	1.1	289.3	030/812	B5/B14							
	4.1	80	1.0	337.5	030/811	B5/B14							
	3.5	80	1.0	405		B5/B14							
	3.2	120	1.0	434	030/812	B5/B14							
	2.4	120	1.0	578.6		B5/B14							
	1.6	120	1.0	867.9		B5/B14							
	1.2	120	1.0	1157		B5/B14							
	1.0	120	1.0	1447		B5/B14							
	0.8	120	1.0	1736		B5/B14							
	0.7	120	1.0	2098		B5/B14							
	0.5	120	1.0	2734		B5/B14							

Nota: Verificare sempre che la coppia M_2 utilizzata non ecceda il valore indicato nelle caselle in grigio
Note: Please check that the output torque M_2 does not exceed the value into the grey areas

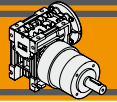

Dimensioni

Dimensions

WMP026/52...U

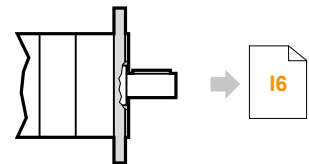
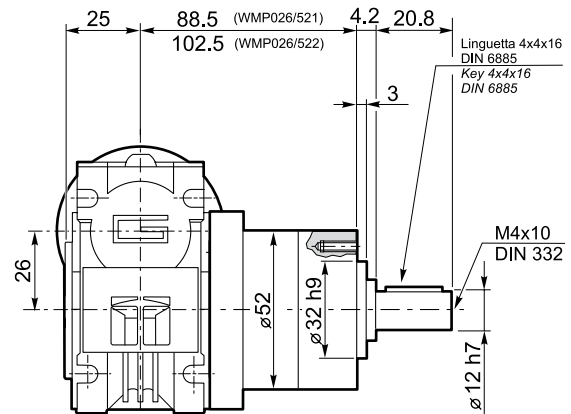
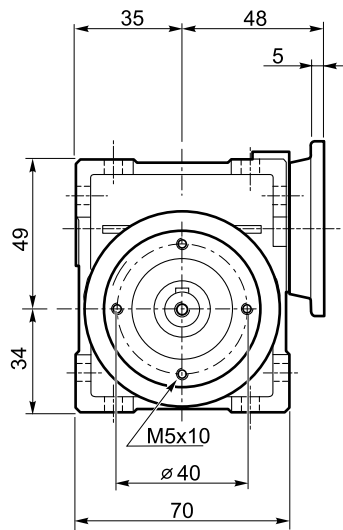

WMP026/52...C

WMP026/62...U

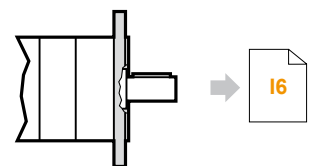
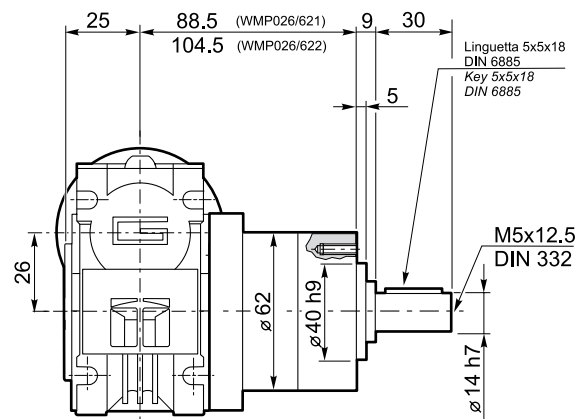
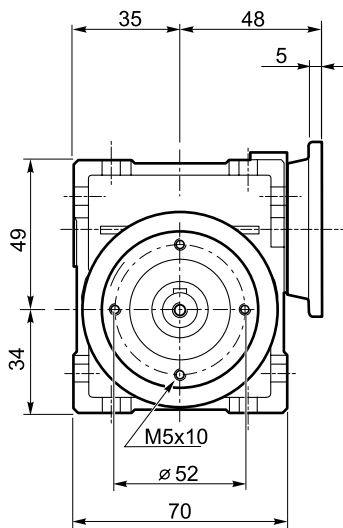

WMP026/62...C

WMP

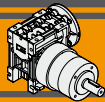

Dimensioni

Dimensions

WMP030/81...U

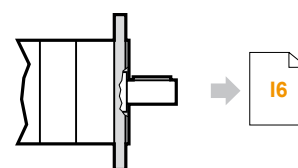
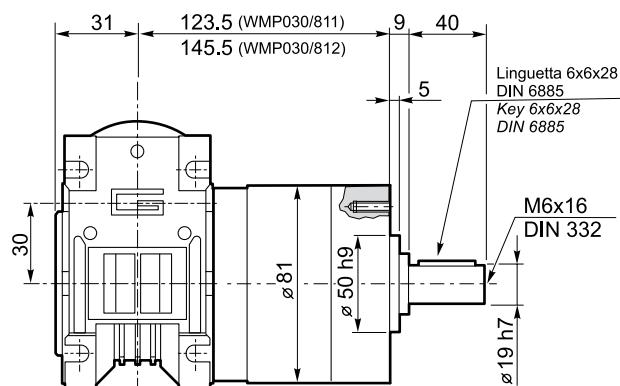
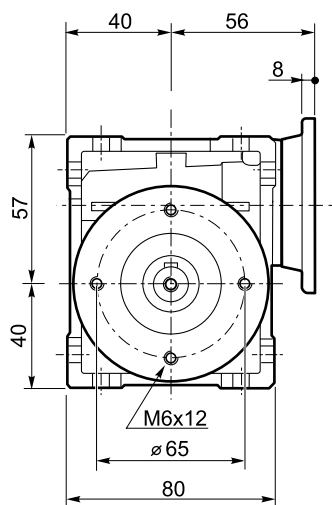

WMP030/81...C

WMP.../.../... C... Flange uscita / Output flanges

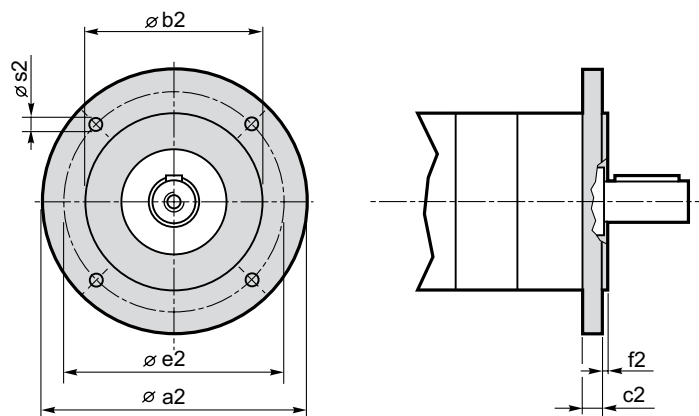

Dimensioni / Dimensions							
P	a2	b2	c2	e2	f2	s2	Flangia uscita Output flange
52	80	50 j7	9	65	2.5	M5	C80
	90	60 j7	9	75	2.5	5.5	C90
	105	70 j7	9	85	2.5	6.5	C105
	120	80 j7	9	100	3.0	6.5	C120
62	80	50 j7	9	65	2.5	M5	C80
	90	60 j7	9	75	2.5	5.5	C90
	105	70 j7	9	85	2.5	6.5	C105
81	90	60 j7	9	75	2.5	M5	C90
	105	70 j7	9	85	2.5	M6	C105
	120	80 j7	9	100	3.0	6.5	C120

Opzioni

Options

VS - Vite sporgente / Extended input shaft

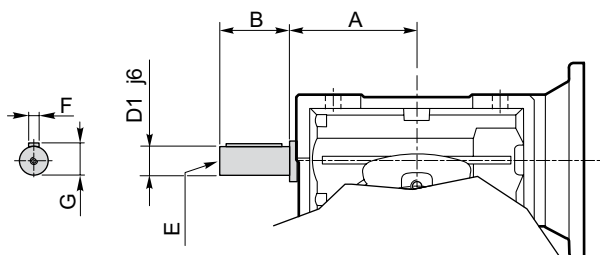

	A	B	$D1 j6$	E	F	G
CM 030	45	20	9	M4	3	10.2